

Vantage FHD

Hi-Tech Dual Discharge
Commercial Air coolers

Instruction manual

Available languages





Index

1	Important information	3
1.1	Disclaimer	3
1.2	Where to find product information	3
2	Product description	3
2.1	General information and application	3
2.2	Standard configuration	3
2.3	Options	4
2.4	Code description	4
3	Product labels	4
4	Unpacking and lifting	5
5	Installation	8
5.1	Mounting dimensions	8
5.2	Mounting bracket	9
5.3	Refrigerant connections.....	10
5.4	Pressure test	11
5.5	Drain line	11
5.6	Electrical connections	12
5.7	Fan motors connections	12
5.8	Electric defrost connections.....	13
6	Maintenance	14
6.1	Electric defrost elements replacement	14
6.2	Fans replacement	14
7	Spare parts	15

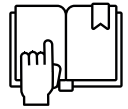

1 Important information



1.1 Disclaimer

This Instruction Manual applies to Vantage FHD air cooler products. Manual must be carefully examined and instructions should be followed up at all times. LUVE does not accept liability for any damage resulting from non-compliance to the instructions as given in the manuals and order-related documents. As the heat exchanger is supplied indirectly, the producer is not acquainted with its actual application.



1.2 Where to find product information

Detailed technical data for individual product models are available in order related documents, on the product label and in product data sheets. Comprehensive technical information for all LUVE air heat exchanger products is available on-line on www.lu-ve.com. This includes:

- Product manuals
- Instruction manuals
- Product leaflets & brochures
- Product data sheets (selection software)
- Dimensional drawings
- Certificates

LUVE offers world-wide service and support. In case of any questions or uncertainty please contact your local LUVE representative. Contact addresses are available at www.lu-ve.com.

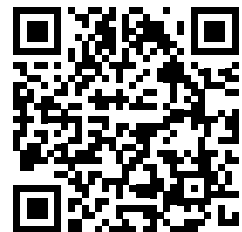

2 Product description

2.1 General information and application

Vantage FHD are commercial dual discharge air coolers for general application in small to medium-sized cooling, freezing and working rooms. Low air velocity and noise level make them especially suitable for refrigerated working and processing rooms.

- Refrigerants: HFC, CO₂ and brine
- Capacity range (R404, DT1): 2,000 up to 19,800 W
- Air volume: 1,400 up to 8,000 m³/h
- Air inlet temperature: -25 to +30 °C
- Fluid inlet temperature: -40 to +20 °C

Model	Refrigerant	Max working pressure
FHDE	HFC	24 bar
FHDX	CO ₂	60 bar**
FHDW	Brine	12 bar

* Fluid group 2 according to EN 378

** 85 bar in special execution

2.2 Standard configuration

- Plastic casing.
- Hinged drain tray. Dismountable and openable casing for cleaning purposes.
- Coil manufactured from internally grooved Cu tubes for HFC and CO₂ models; smooth Cu tubes for brine models.
- High-efficiency louvered aluminum fins.
- Standard fin spacing 3.0, 4.5 and 7.0 mm.
- 1 to 4 fans fitted with EC fan motors available in two fan speeds (noise levels): S=High

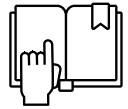

Speed (1100 RPM) and L=Low Speed (870 RPM). Fan diameter Ø 350 mm. Power supply 230V/50-60Hz/1.

- Fan motors wired to connection box.
- Vertical plastic drain connection.
- Each heat exchanger is leak tested with dry air and finally supplied with a dry air pre-charge.
- Delivered on a wooden pallet, either covered with a reinforced cardboard box or a wooden crate.

2.3 Options

- Stainless steel tubes (AISI 304)
- Coil protection: pre-coated aluminium fins (AP)
- Electric defrost in coil
- Electric defrost in drain tray (unwired)
- EC fan motor with 0-10 V control input (0-10)
- Threaded connections for brine units.

2.4 Code description

FHD	*	711	N	4	*	*
1	2	3	4	5	6	7

- 1 Dual discharge commercial air coolers
- 2 Refrigerant system (blank=HFC, W=brine, in case of CO₂ see pos. 6)
- 3 Model type
- 4 Defrost system (N=air defrost, E=electric defrost)
- 5 Fin spacing (3=3.0, 4=4.5, 7=7.0 mm)
- 6 Application (DX CO₂=direct expansion for CO₂)
- 7 Circuits code - only for brine units

3 Product labels

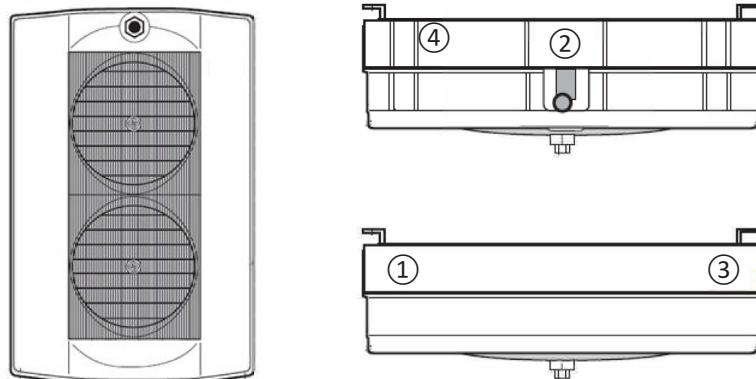

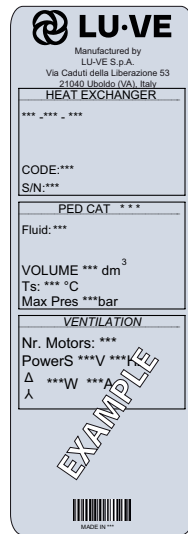
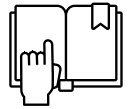

1. Product label

Model	Refer to paragraph "2.4 Code description"
Product code Product Serial nr.	Communicate these when ordering spare parts as they identify the unit
PED Category	According to PED
Fluid	Refrigerant
Volume	Coil Volume
Ts	Range of operating temperatures for the coil
Max Pres	Max working pressure
Nr Motors	Number of fans

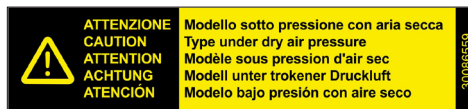

2. Precharge warning

Units are delivered from the manufacturer with an overpressure. Check pressure on the Schrader valve. With unpressurised unit: immediate report to manufacturer and note on bill of delivery.



3. Electrical warning

Electrically powered component. Switch off power supply before any maintenance or installation activity.

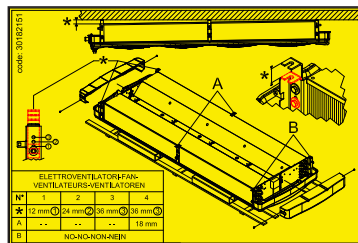

4. Ceiling mounting instructions

When mounting the unit to the ceiling, consider the slope.

4 Unpacking and lifting



Vantage FHD air coolers are delivered on a wooden pallet, either covered with a reinforced cardboard box or a wooden crate. Handling and positioning can take place manually (smaller models) or with use of a forklift.

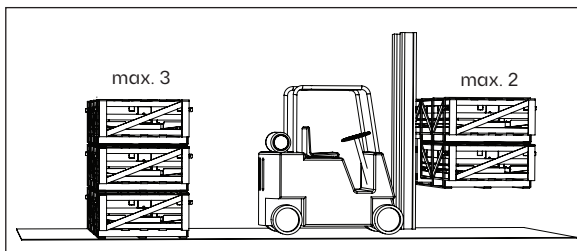

Packed air coolers may be stacked during transportation (max. 2) and storage (max. 3). Respect the maximum number of stacked air cooler units.

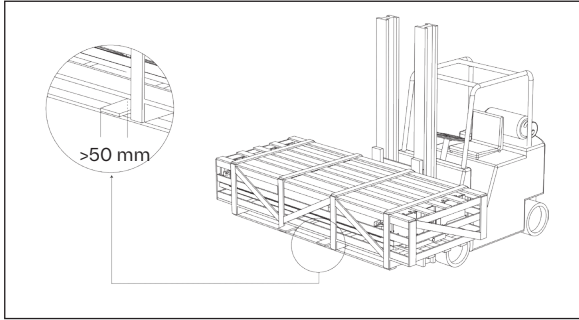
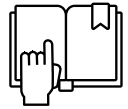

In order to avoid damage to the air cooler or falling of the unit, ensure that the lifting forks cover all beams from the lower support pallet.

Casing type 1 and 2 models packed with cardboard box must be turned.

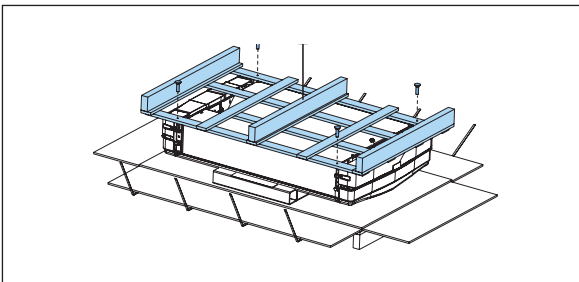
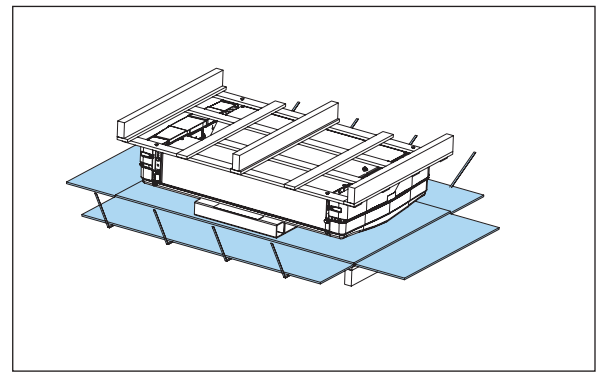
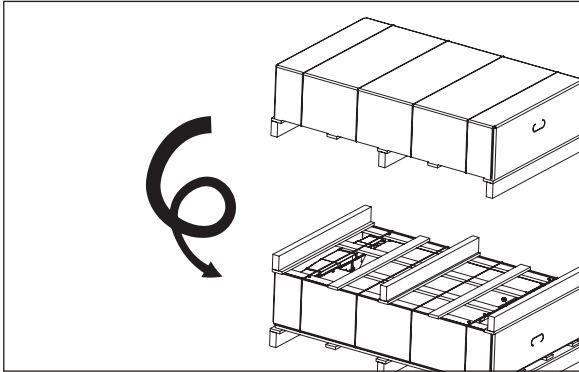

Place the unit on the ground and manually turn the air cooler into mounting position on a second wooden pallet. Keep the packaging material in place to prevent the drip trays from damaging. Flatten the cardboard sides and remove the original support pallet (now on top). The cooler is now in mounting position.

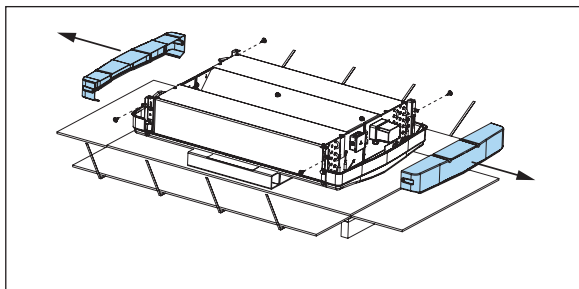

Remove side covers by loosening screws. Remove the transparent protection film from painted metallic parts, if present.

Casing type 3 and 4 models packed with crate must be turned.

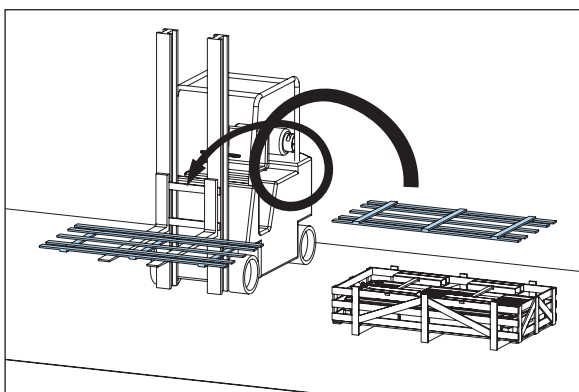

Place the unit on the ground. Unscrew the top pallet and turn it on the forklifts forks.

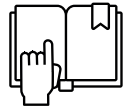

Remove the side panels of crate. Unscrew the unit from the lower pallet.

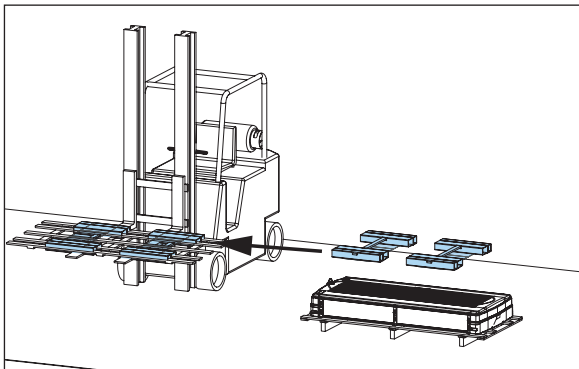
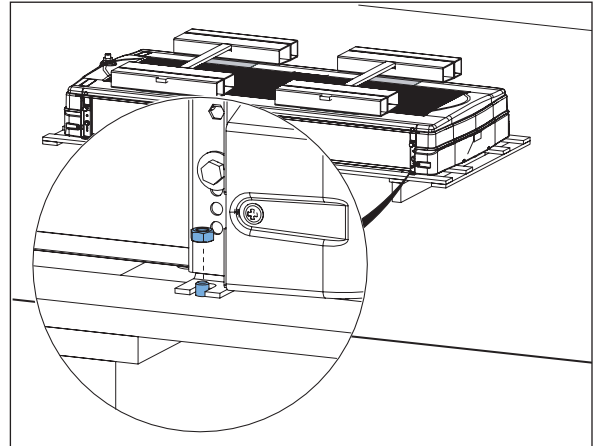
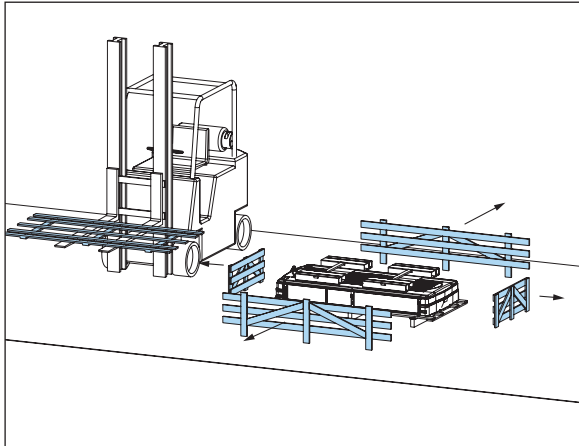

Move the cardboard supports onto the pallet placed on the forklift.

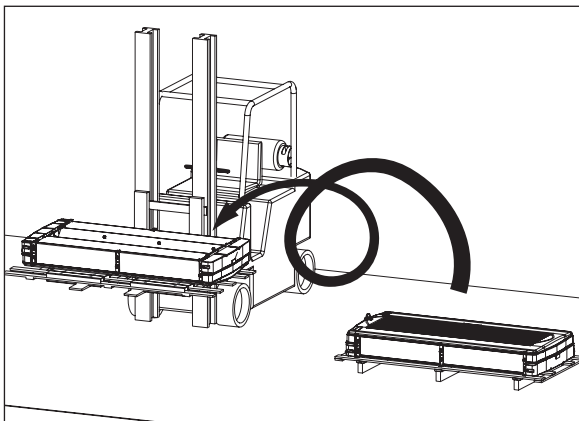

Turn the unit onto the cardboard supports now placed on the forklift. The cooler is now in mounting position.

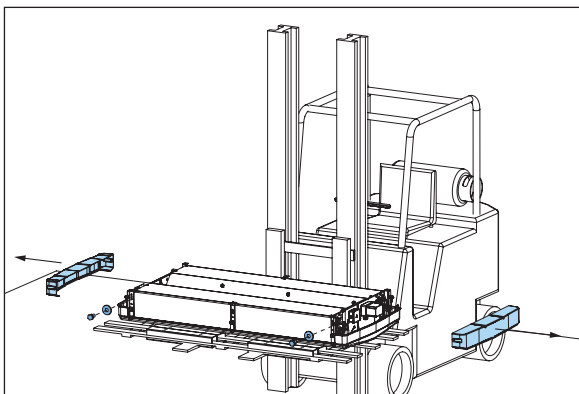

Remove the side covers.

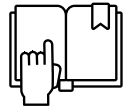

When lifting the unit by using the forklift:

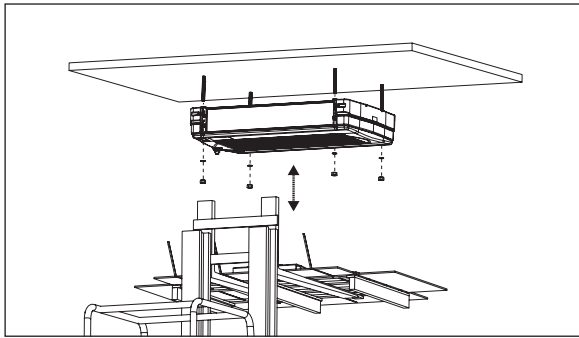

Ensure that the cooler is not lifted directly onto the drip tray or the finned coil. Utilizing the proper wooden transport support and/or pallets prevents the cooler bending at the extremes such that the cooling circuit or other components are damaged. Lift the unit to mounting position and secure following instructions given in chapter "5 Installation". After having secured the cooler, the forks may be lowered and the remaining packaging materials can be removed.

5 Installation

5.1 Mounting dimensions

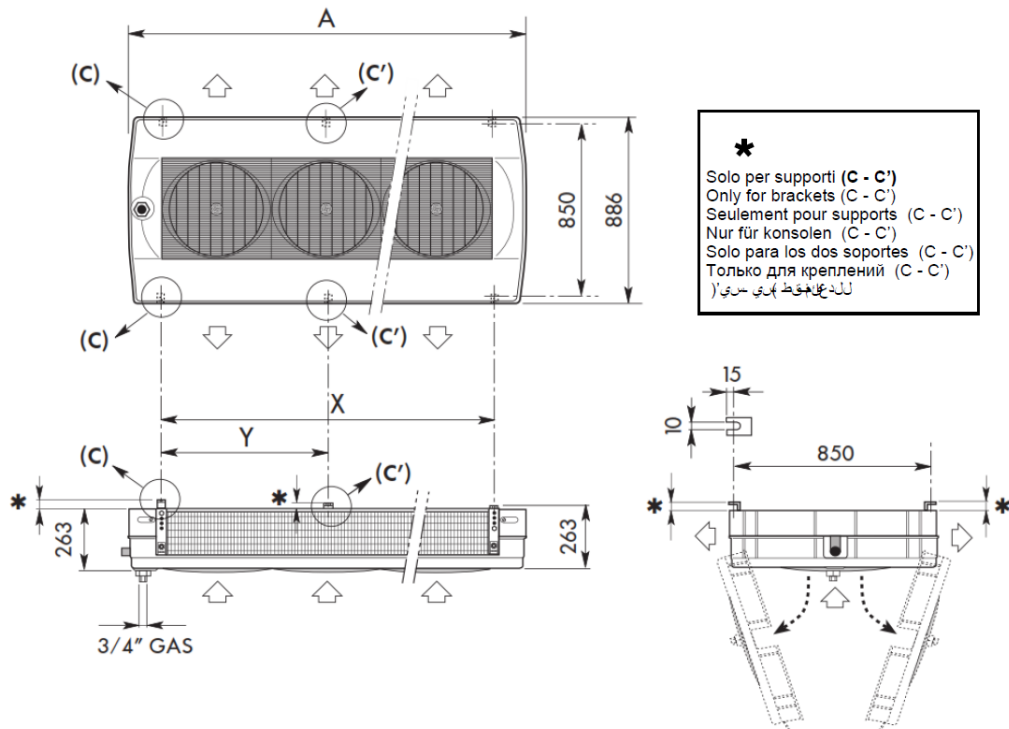

	711-3 811-4 911-7	712-3 812-4 912-7	721-3 821-4 921-7	722-3 822-4 922-7	732-3 832-4 932-7	742-3 842-4 942-7
No. fans	1	1	2	2	3	4
A	886	886	1,443	1,443	1,998	2,553
X	596	596	1,151	1,151	1,706	2,261
Y	-	-	-	-	-	1,130
IN	12	12	12	16	16	16
OUT	22	28	28	35	35	35

Weight information are listed on the product label and/or in the relevant product documentation.

Detailed drawings showing all required mounting and refrigerant connection dimensions are available for download on www.lu-ve.com.

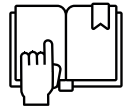

5.2 Mounting bracket

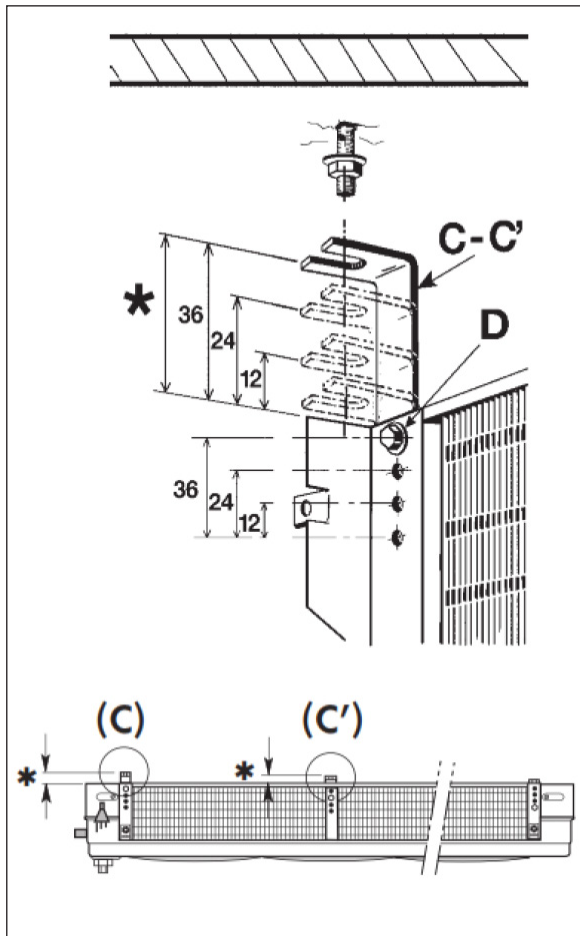

Place the brackets (C and C') in the installation position by first unscrewing and then re-screwing the screws (D). Ensure to consider the required slope for the unit.

No. fans	C (mm)	C' (mm)
1	12	-
2	24	-
3	36	-
4	36	18

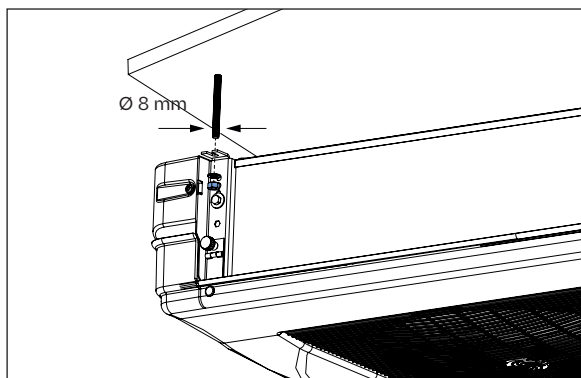

Use suitable studs when mounting the unit to the ceiling. Fix the unit to cold room ceiling by securely tightening nuts and washers.

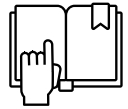

5.3 Refrigerant connections

Do not adapt headers position to the suction line.

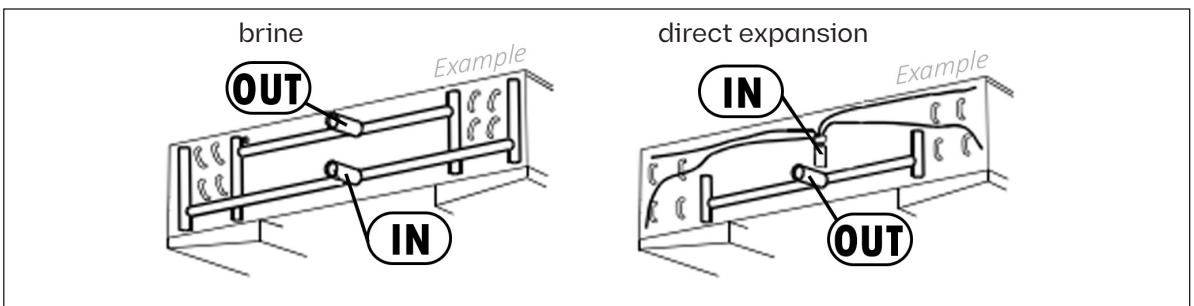
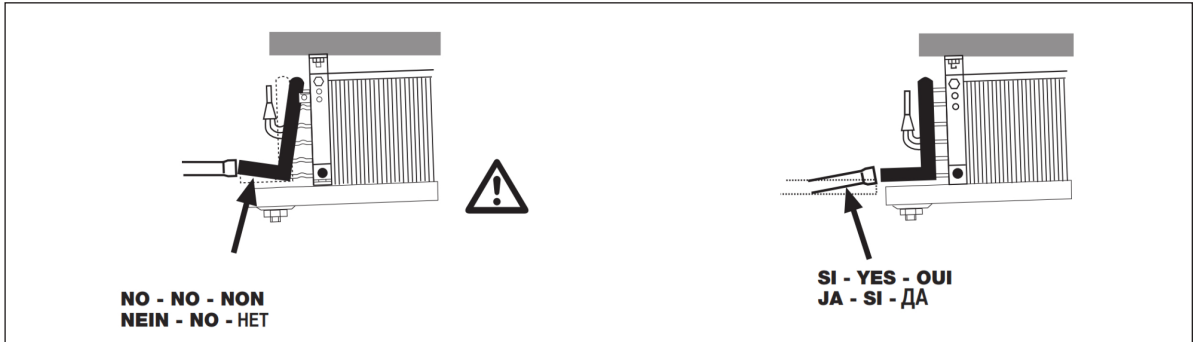

Always check the connections diameter on the data sheet.

For special products or when in doubt about connections, it is advisable to ask for a detailed drawing.

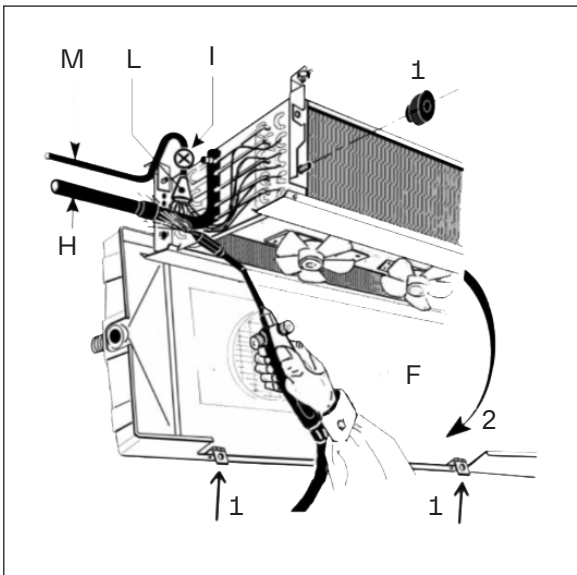

For direct expansion application, ensure the supply circuit is closed (no pressure) before connecting the suction lines.

Remove the fixing material (1) and open (2) the drain tray (F). Connect the suction line (H), the thermostatic valve (I) to distributor (L) and the liquid line (M).

Ensure the flame nozzle is not aimed at the equipment, when welding. Insert a protection shield if required.

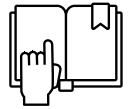

5.4 Pressure test

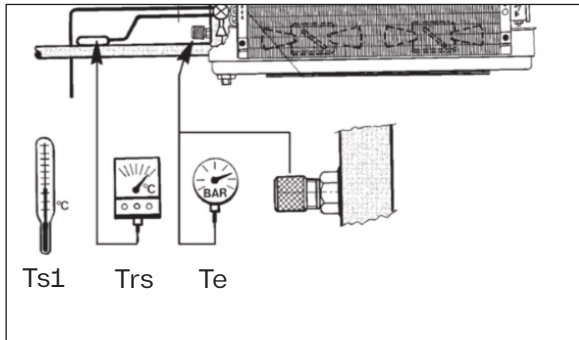

Ts1=cold room air inlet temperature.
 Te=evaporating temperature. It is related to the refrigerant pressure on the unit cooler outlet.
 Trs=refrigerant superheat temperature, on suction line near thermostatic valve bulb.
 (Trs-Te)=superheat
 $(Trs-Te) \leq 0.7 \times (Ts1-Te)$

Keep the superheat as low as possible to obtain maximum unit cooler performance. The thermostatic valve fitted must be correctly sized for the installation conditions and adjusted for correct system operation.

5.5 Drain line

Check all drain lines and drain trays to ensure that no improper material such as, e.g., packaging material blocks the drain.

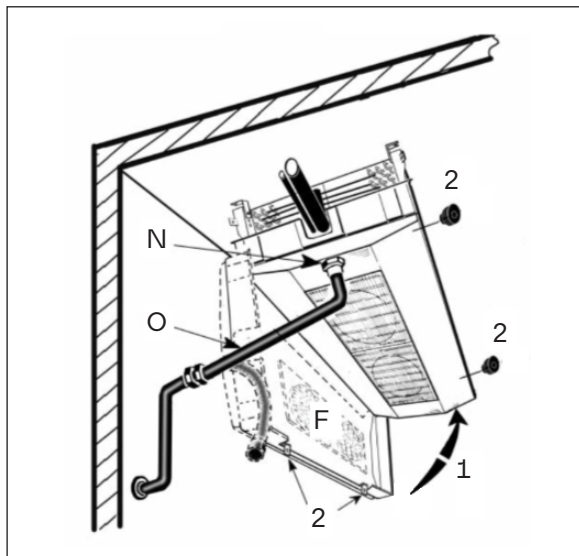

Close the drain tray and connect the drain tubing (O) to the drain connection (N).

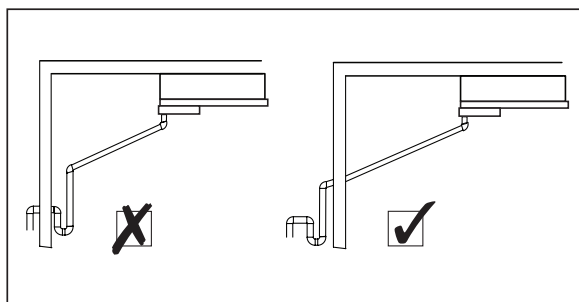

The drain line diameter must be at least the size of the drain tray drain diameter and should be laid with an adequate slope. For room temperatures below 0 °C drain line insulation and defrosting are required.

A syphon must be installed on the drain line, outside the cold room.

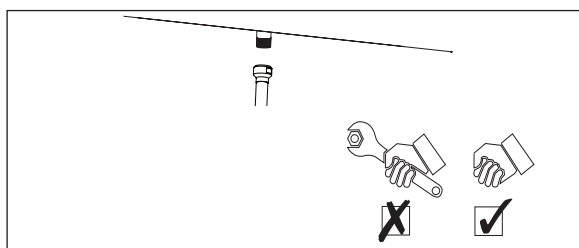

Tighten drain connection by hand only.

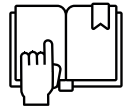

5.6 Electrical connections



The following data determine which connection diagram is to be selected and respected for electrical installation:

- Heat exchanger model indication
- Fan motor type
- Electrical options



When in doubt always contact your local supplier or LUVE representative for assistance. Ensure complete electrical isolation before performing any wiring.

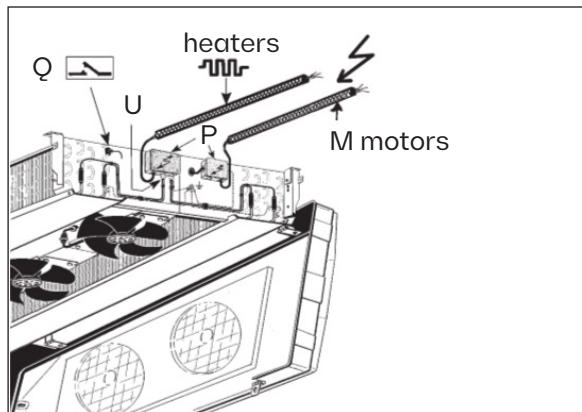

Remove the terminal block cover (P). Insert the cables into the grommet (U) and block them with their respective gland. Connect terminals by following the wiring diagrams on the cover. When all connections are made refit the terminal block cover. For systems using electrical/hot gas defrost, a defrost termination thermostat should be used, having a range of 10 °C to 20 °C with a sensor attached to the top return bends of the coil block or buried in the top of the coil block fins (Q).

Differential protections and circuit breakers are not included in the scope of supply.

5.7 Fan motors connections



Ensure complete electrical isolation before performing any wiring.

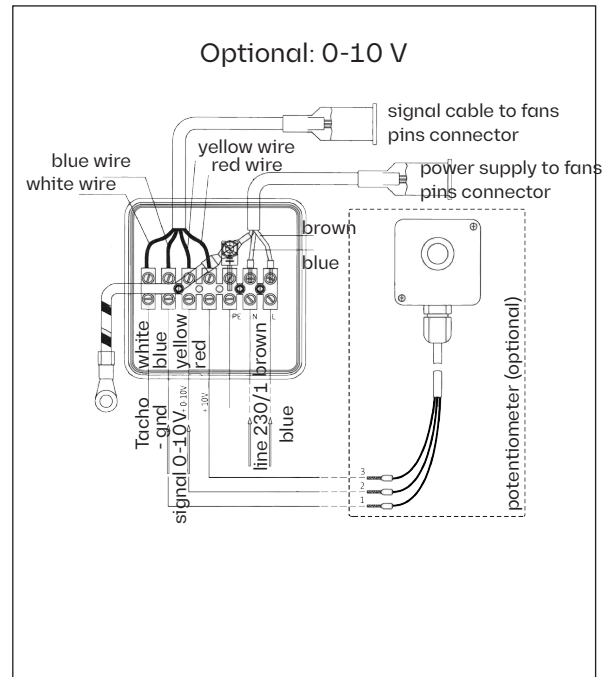
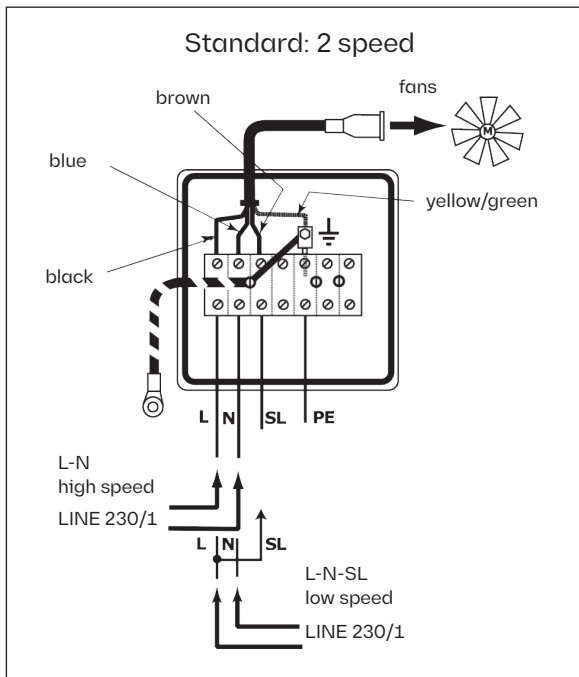

Motor power consumption (x1)

Speed	H = High Speed (1100 RPM)	L = Low Speed (900 RPM)
EC 1~230 V - 50/60 Hz	85 W 0.7 A	42 W 0.4 A

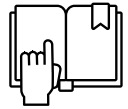

5.8 Electric defrost connections

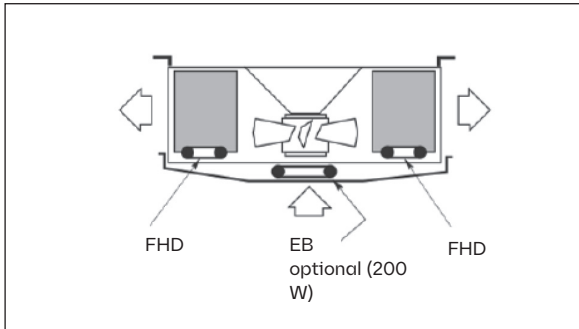

FHD = Electric defrost in coil
EB = Electric defrost in drain tray (unwired)

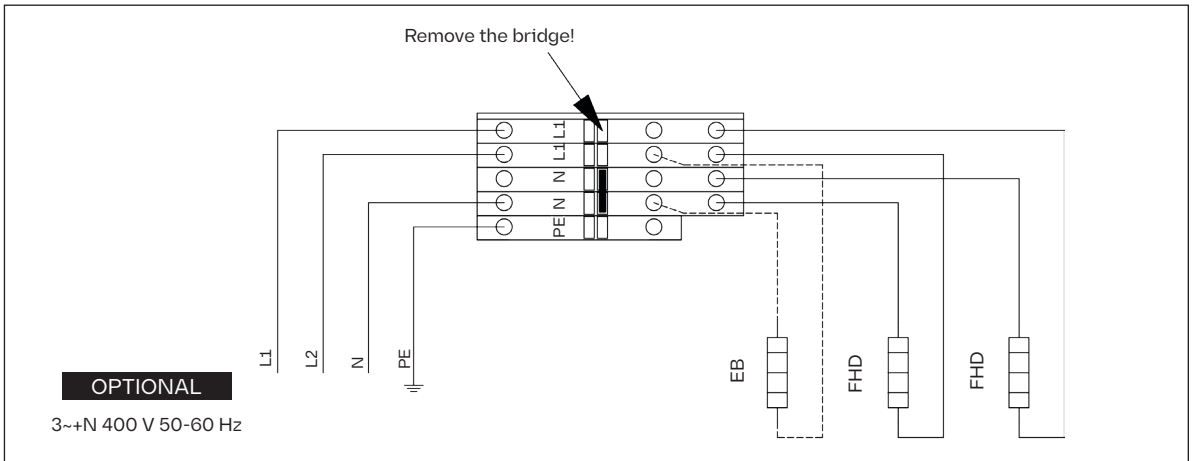
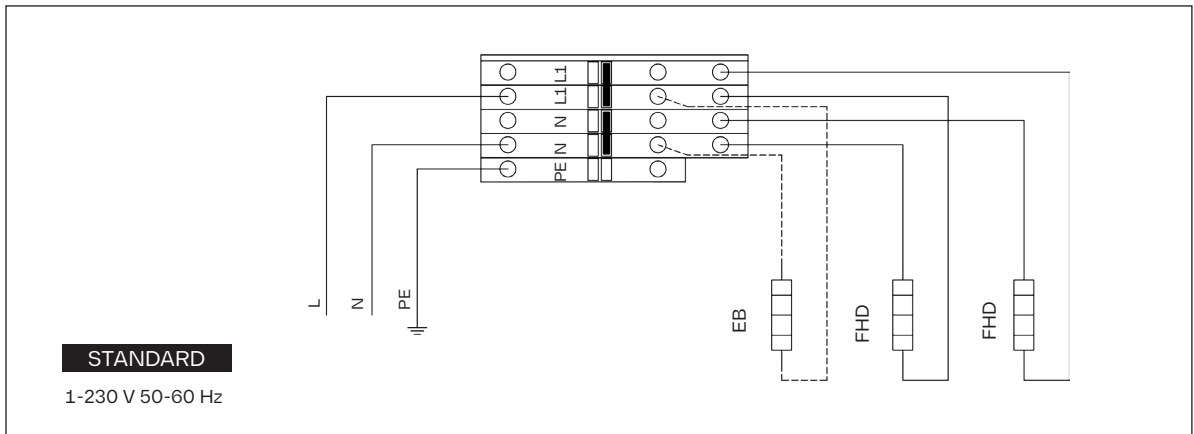

No. fans	Electric defrost in coil (E)		
	no.	W (x1)	W tot
1	2	900	1800
2	2	1600	3200
3	2	2350	4700
4	2	3100	6200

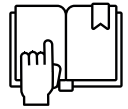

6 Maintenance



Ensure complete electrical isolation before performing any maintenance activity.



6.1 Electric defrost elements replacement

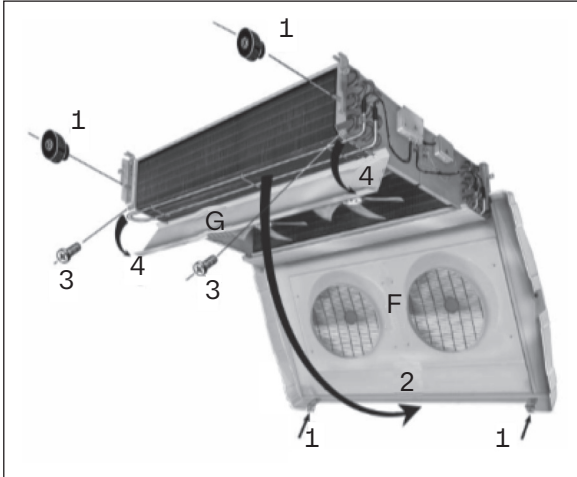

Always disconnect power supply before handling heater elements. Disconnect drain line. Remove fixing bolts and open the drain tray (F) and the bottom plate (G).

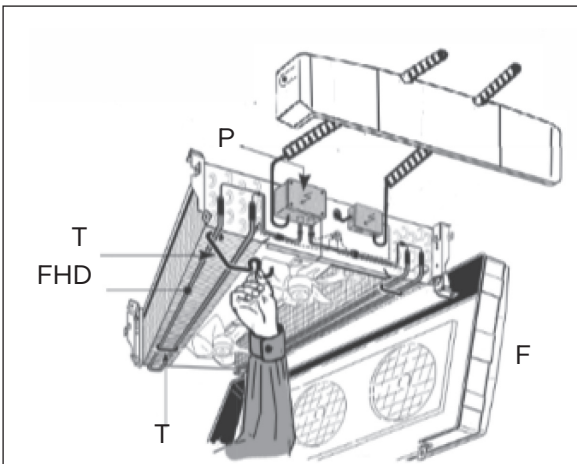

Open side covers. Remove fixing clips (T), disconnect heater elements from connection box (P) and extract elements (FHD). Mount new elements in reverse order, close side covers and restore electrical connections.



6.2 Fans replacement

Open the drain tray. Disconnect the electric supply (R). Unscrew fixing bolts and remove old fan. Mount new fan in identical position. Use an anti-corrosion compound when remounting the fixing bolts.

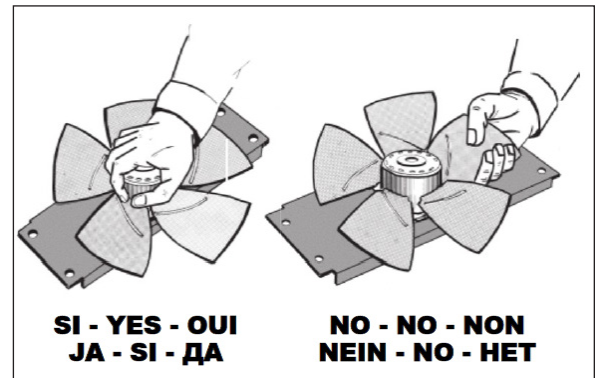
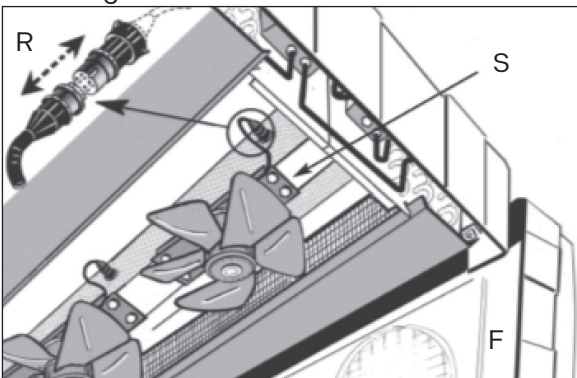

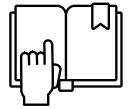

7 Spare parts

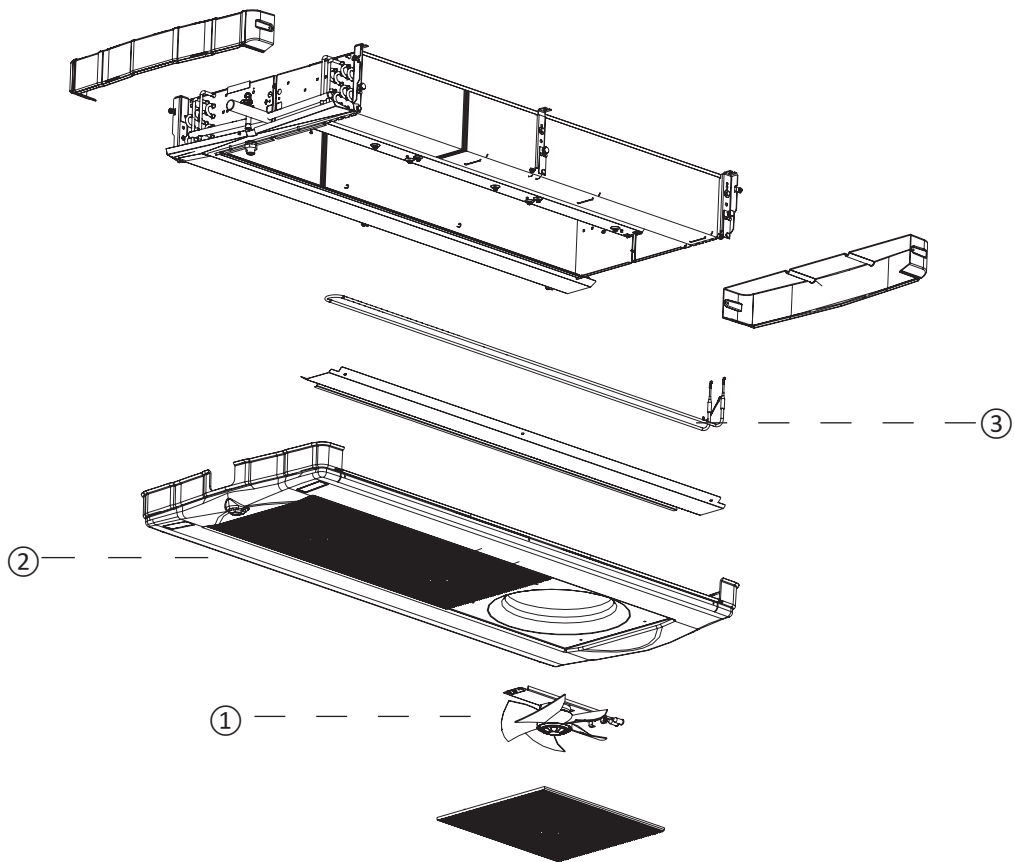

Spare parts

- | | |
|---|--|
| 1 | Fan motor |
| 2 | Drip tray kit |
| 3 | Electric heater |
| 4 | Drip tray heater (optional, not shown) |

Contact your local LUVE representative for spare parts order and assistance.

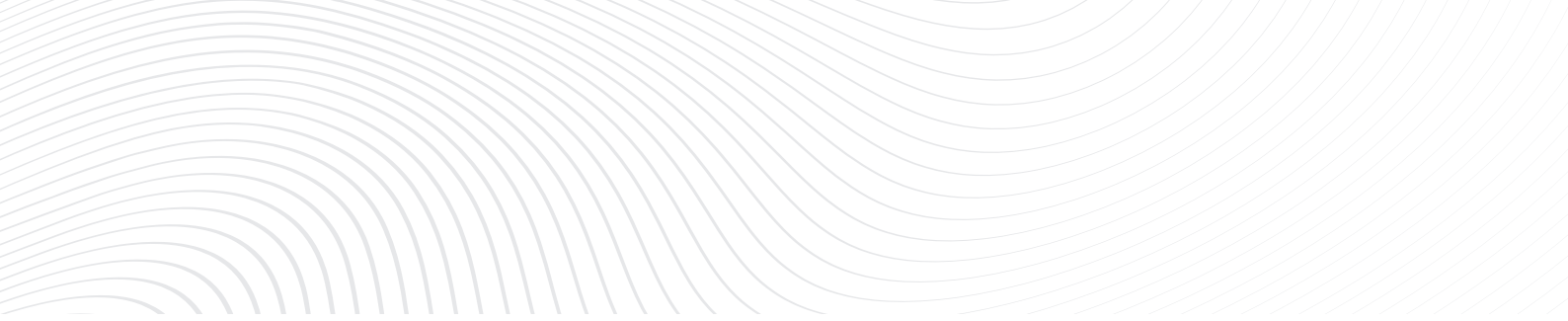

LU·VE

LUVE S.p.A. - The shape of cooling

Via Caduti della Liberazione, 53 - 21040 Uboldo (VA) - Italy

www.lu-ve.com