



# Defender CD | CRD

Hi-tech dual discharge industrial  
Air coolers

**Instruction manual**

Available languages

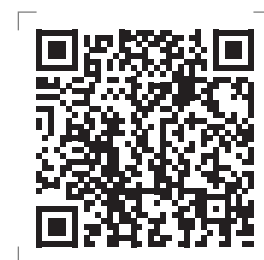



## Index

<b>1</b>	<b>Important information</b> .....	<b>3</b>
1.1	Disclaimer .....	3
1.2	Where to find product information .....	3
<b>2</b>	<b>Product description</b> .....	<b>3</b>
2.1	General information and application .....	3
2.2	Standard configuration .....	3
2.3	Options .....	4
2.4	Code description .....	4
<b>3</b>	<b>Product labels</b> .....	<b>5</b>
<b>4</b>	<b>Unpacking and lifting</b> .....	<b>7</b>
<b>5</b>	<b>Installation</b> .....	<b>9</b>
5.1	Mounting dimensions .....	9
5.2	Mounting bracket .....	9
5.3	Technical spaces .....	9
5.4	Refrigerant connections.....	9
5.5	HFC and CO <sub>2</sub> refrigerant .....	10
5.6	Ammonia refrigerant.....	10
5.7	Brine refrigerant .....	10
5.8	Pressure test .....	11
5.9	Drain line .....	11
5.10	Electrical connections .....	12
5.11	Fan motor connections, AC axial fans.....	12
5.12	Fan motor connections, EC axial fans.....	14
5.13	Fan motor connections, EC radial fans .....	15
5.14	Electric defrost.....	16
5.15	Hot-gas connections .....	16
5.16	Hot-gas defrost (G) .....	16
5.17	Hot-gas defrost both in coil and drain tray (GB) .....	17
5.18	Hot glycol defrost.....	17
<b>6</b>	<b>Maintenance</b> .....	<b>18</b>
6.1	Side panel opening.....	18
6.2	Drain tray opening.....	18
6.3	Electric defrost elements replacement .....	19
6.4	Fan replacement (CD units) .....	20
6.5	Hinged fan opening (CRD units) .....	20
6.6	Fan replacement (CRD units).....	21
<b>7</b>	<b>Spare parts</b> .....	<b>22</b>
7.1	CD units .....	22
7.2	CRD units .....	23

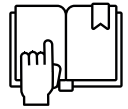

# 1 Important information

## 1.1 Disclaimer



This Instruction Manual applies to dual discharge industrial air cooler products Defender CD and CRD. Manual must be carefully examined and instructions should be followed up at all times. LUVE does not accept liability for any damage resulting from failure to comply with or incomplete compliance with the instructions as given in the manuals and order-related documents. As the heat exchanger is supplied indirectly, the producer is not acquainted with its actual application.

## 1.2 Where to find product information

Detailed technical data for individual product models are available in order related documents, on the product label and in product data sheets. Comprehensive technical information for all LUVE air heat exchanger products is available online on [www.lu-ve.com](http://www.lu-ve.com).

This includes:

- Product manuals
- Instruction manuals
- Product leaflets & brochures
- Product data sheets (selection software)
- Dimensional drawings
- Electrical wiring diagrams
- Certificates

LUVE offers world-wide service and support. In case of any questions or uncertainty please contact your local LUVE representative.

Contact addresses are available at [www.lu-ve.com](http://www.lu-ve.com).

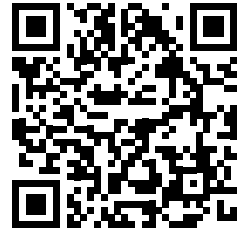

Defender CD



Defender CRD

# 2 Product description

## 2.1 General information and application

CD are high performance dual discharge industrial air coolers fitted with axial fans for cold rooms in industrial applications.

CRD are dual discharge air coolers fitted with EC radial fans for cooling and freezing applications in medium to large cold rooms. This industrial air cooler line is designed to improve acoustic comfort of workers inside cold rooms and increase product sustainability.

- Refrigerants: HFC, ammonia, brine, CO<sub>2</sub>
- Capacity range CDH (R404, SC2): 6 up to 92 kW
- Capacity range CRDH (R404, DT1): 15 up to 122 kW
- Air volume: 4,600 up to 45,200 m<sup>3</sup>/h

Model	Refrigerant application	Design pressure
CDH, CRDH	HFC	24 bar*
CDA	Ammonia	22 bar
CDH CO <sub>2</sub> , CRDH CO <sub>2</sub>	CO <sub>2</sub>	45 bar
CDW, CRDW	Brine	24 bar*

\* Higher pressure levels on request

## 2.2 Standard configuration

- Finned coil:

Refrigerant application	Fins material	Tubes material	Headers material
HFC	Al*	Cu	Cu
Ammonia	Al*	Stainless steel 304**	Stainless steel 304**
CO <sub>2</sub>	Al*	Cu***	Cu
Brine	Al*	Cu	Cu

\* Alupaint as optional; \*\*Stainless steel 316 on request; \*\*\* increased thickness

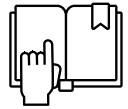

- High-efficiency TURBOFIN® aluminum fins with special configuration of the louvre profile to reduce dehumidification and frost formation.
- High-efficiency small-diameter copper tubes with internal helical grooving, designed for optimal evaporation of the refrigerant fluids. Stainless steel tubes for ammonia refrigerant.
- Standard fin spacings 4.5, 6, 7.5 and 10 mm.
- CD units are fitted with 1 to 4 axial fans with high-efficiency AC or EC fan motors blowing through the coil. Available in different fan diameters (ø 450, 500 and 630 mm).
- CRD units are fitted with 1 to 4 radial EC fans with diameter ø 630.
- Integrated thermo contacts provide reliable protection against thermal overload.
- Corrosion-resistant galvanized steel casing, epoxy coated RAL 9003.
- Each heat exchanger is leak tested with dry air and finally supplied with a dry air pre-charge. Fitted with schröder valve on the suction connection for testing purposes (only for HFC units).

### 2.3 Options

- Corrosion protection: Alupaint
- Unit cooler switches
- Unit cooler wiring
- Fan switch (IS)
- Insulated drain tray
- Stainless steel casing and coil frame
- Hinged fan shroud
- Electric defrost (E)
- Hot-gas defrost in coil + electric defrost in drain tray (G)
- Hot-gas defrost both in coil and drain tray (GB)
- Hot glycol defrost both in coil and drain tray (HG)
- Draw-trough fan
- Top fan
- AVA connection - *for brine application*

### 2.4 Code description

<b>CD</b>	<b>63</b>	<b>H</b>	<b>*</b>	<b>8608</b>	<b>E</b>	<b>6</b>	<b>*</b>
1	2	3	4	5	6	7	8

- 1 Defender dual discharge industrial air cooler (CD=with axial fans, CRD=with radial fans)
- 2 Fan diameter (45=450 mm, 50=500 mm-4P, 52=500 mm-6P, 63=630 mm-6P, 64=630mm-4P)
- 3 Technology (H=Hitec® for HFC and CO<sub>2</sub>, blank=for ammonia and brine)
- 4 Refrigerant system (blank=HFC, A=ammonia, W=brine, in case of CO<sub>2</sub> see pos. 8)
- 5 Model type
- 6 Defrost system (N=air defrost, E=electric defrost, G=hot-gas defrost in coil + electric defrost in drain tray, GB=hot-gas defrost both in coil and drain tray)
- 7 Fin spacing (4=4.5 mm, 6=6.0 mm, 7=7.5 mm, 10=10.0 mm)
- 8 Application (DX CO<sub>2</sub>=direct expansion for CO<sub>2</sub>, PB=pumped bottom feed for ammonia, PT=pumped top feed for ammonia)

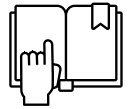

### 3 Product labels

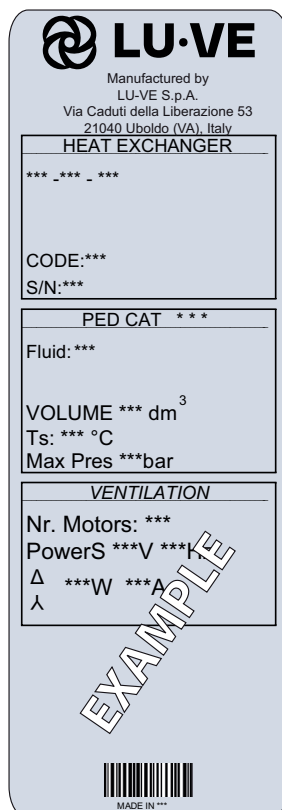
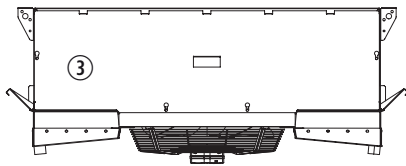
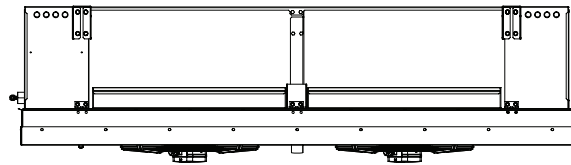
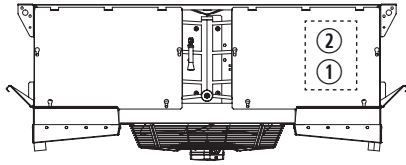

#### 1. Product label

For units working with with PED I refrigerants.  
 This label is positioned inside the casing.

Model	Refer to paragraph "2.4 Code description"
Product code Product serial nr.	Communicate this when ordering spare parts as they identify the unit
PED Category	According to PED
Fluid	Refrigerant
Volume	Unit volume
Coil Ts	Range of operating temperatures for the coil
Max Pres	Max pressure
Nr. Motors	Number of fans
Motors	Fan motors power supply

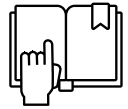

For units working with with PED II refrigerants.



**21040-UBOLDO-ITALY**  
**HEAT EXCHANGER**

CODE: 31636988  
S/N: 10698964/2021  
FLUID: NH3  
FLUID GROUP: 1

DESIGN PRESS.:

INT.PSbar.g: 24P Atm  
EXT. PSbar: P Atm

TEST PRESS.  
PTbar.g: 35P atm

DESIGN TEMP.

EXT.TS °C -40/55  
INT.TS °C -40/120

CAPACITY: 55,40 L  
TEST PRESS. DATE

15/02/2023

PED Cat: II  
Made in Italy



0425



**ATTENZIONE**  
**CAUTION**  
**ATTENTION**  
**ACHTUNG**  
**ATENCIÓN**

**Modello sotto pressione con aria secca**  
**Type under dry air pressure**  
**Modèle sous pression d'air sec**  
**Modell unter trokener Druckluft**  
**Modelo bajo presión con aire seco**

30086599

## 2. Precharge warning

Only for HFC and CO<sub>2</sub> units.

Units are delivered from the manufacturer with an overpressure. Check pressure on the Schrader valve. With unpressurised unit: immediate report to manufacturer and note on bill of delivery.



**MOTORI PROTETTI TERMICAMENTE**  
**OVERLOAD PROTECTED MOTORS**  
**ВЕНТИЛЯТОРЫ С ЗАЩИТОЙ ОТ ПЕРЕГРУЗКИ**  
**MOTOREN MIT ÜBERLASTUNGSSCHUTZ**  
**MOTORES CON PROTECCION TERMICA**  
**المحركات المحمية الحرارية**

<p><b>ATTENZIONE</b></p> <p><b>TOGLIERE CORRENTE PRIMA DI APRIRE</b></p> <p>EVITARE CHE IL VENTILATORE POSSA ESSERE AVVICINATO DA PERSONE NON AUTORIZZATE, BAMBINI O ANIMALI. RIMOVERE LA PROTEZIONE DEL VENTILATORE DOPO AVER TOLTO CORRENTE AL MOTORE. MUNIRE L'APPARECCHIO DI PRESA DI TERRA REGOLARMENTE SECONDO LE NORME.</p>	<p><b>ATTENTION</b></p> <p><b>CUT CURRENT BEFORE OPENING</b></p> <p>AVOID THAT THE FAN BE APPROACHED BY NON-AUTHORIZED PERSONS CHILDREN OR ANIMALS. REMOVE THE FAN PROTECTION ONLY AFTER HAVING CUT OUT THE MOTOR CURRENT THE UNIT MUST BE EQUIPPED WITH REGULAR GROUND CONNECTION ACCORDING TO THE REGULATIONS IN FORCE.</p>
<p><b>ВНИМАНИЕ</b></p> <p><b>ОТКЛЮЧИТЕ НАПРЯЖЕНИЕ ПЕРЕД СНЯТИЕМ</b></p> <p>НЕ ДОПУСКАЙТЕ, ЧТОБЫ К ВЕНТИЛЯТОРУ ПРИБЛИЖАЛИСЬ ПОСТОРОННИЕ ЛИЦА, ДЕТИ ИЛИ ЖИВОТНЫЕ. СНИМАЙТЕ ЗАЩИТУ ВЕНТИЛЯТОРА ТОЛЬКО ПОСЛЕ ОТКЛЮЧЕНИЯ НАПРЯЖЕНИЯ. УСТРОЙСТВО ДОЛЖНО БЫТЬ ОБОРУДОВАНО СТАНДАРТИМ ЗАЗЕМЛЕНИЕМ В СООТВЕТСТВИИ С ДЕЙСТВУЮЩИМИ НОРМАМИ.</p>	<p><b>ACHTUNG</b></p> <p><b>VOR DEM OFFNEN STROM AUSSCHALTEN</b></p> <p>UNBEFUGTEN IST AUFENTHALT IN DER NÄHE DES VENTILATORS STRENGSTENS UNTERSAGT. BESONDERS AUF KINDER UND TIERE. ACHTEN, DIE ABNAHME DES SCHUTZGITTERS DARF NUR BEI AUSGESCHALTETEM MOTOR ERFOLGEN. GEMÄSS DEN VORSCHRIFTEN MUSS DAS GERÄT UNBEDINGT GEERDET SEIN.</p>
<p><b>ATENCIÓN</b></p> <p><b>CORTAR LA CORRIENTE ANTES DE LA APERTURA</b></p> <p>EVITE QUE EL VENTILADOR SEA ABORDADO POR PERSONAL NO AUTORIZADO, NIÑOS O ANIMALES. RETIRE LA PROTECCION DEL VENTILADOR SOLO DESPUES DE HABER CORTADO LA CORRIENTE DEL MOTOR. LA MAQUINA DEBE ESTAR EQUIPADA CON UNA ADECUADA CONEXION A TIERRA SEGUN LAS NORMAS EN VIGOR.</p>	<p><b>الخطر</b></p> <p><b>قطع التيار قبل الافتتاح</b></p> <p>تجنب استخدام المحركين من قبل أشخاص غير مأذون لهم أو أطفال أو حيوانات. أزل الحماية فقط بعد إزالة قوة المحرك. التجهيز من المعيار الأرضي بشكل مستقيم وفقاً للمعايير.</p>

## 3. Overload protected motors warning

Cut out power supply before any maintenance or installation activity.

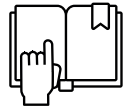

## 4 Unpacking and lifting



Always follow guidelines and instructions as given in the air coolers product manual. Defender CD and CRD models are delivered in mounting position on a wooden pallet covered with a wooden crate. Handling and positioning can take place with use of a forklift.

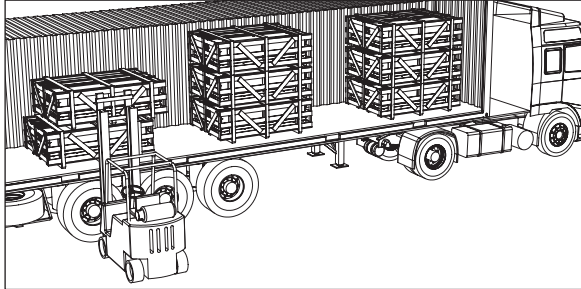

When more coolers are delivered in a single shipment, packed air coolers may be stacked during transportation (max. 3 units). Packed air coolers are to be unloaded one by one. Units must be unloaded and handled only from the long side, one at a time.

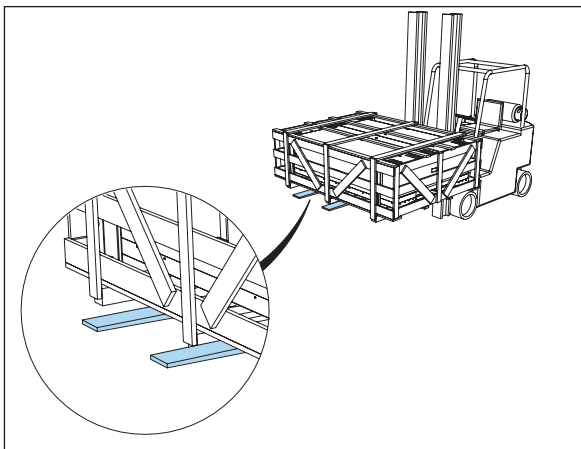

In order to avoid damage to the drain tray or falling of the unit, ensure that the lifting forks cover all beams from the lower support pallet.

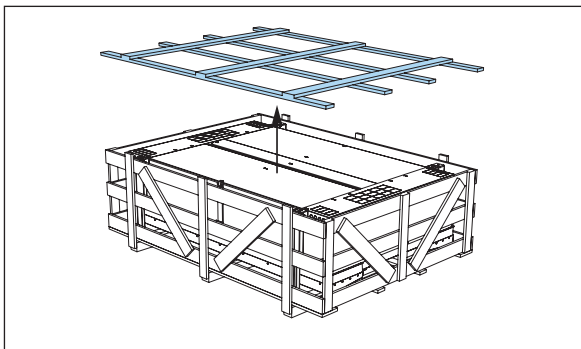

Place the unit on the ground and loosen the fixing materials from the top pallet. Remove the top pallet.

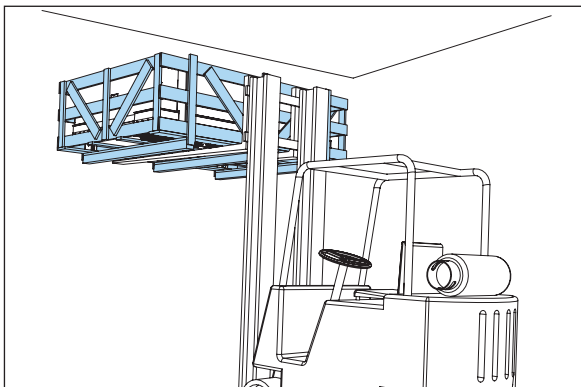

Lift the unit into mounting position and secure following instructions given in chapter "5 Installation".

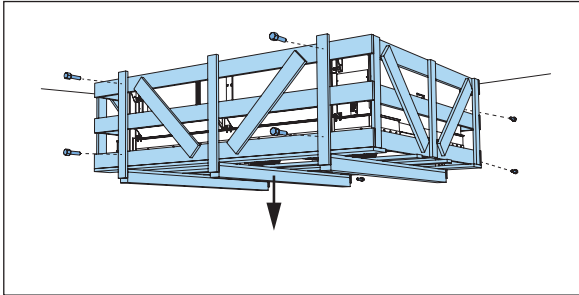
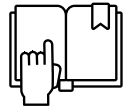

Once the unit is secured in the installation position, remove the fixing materials from the crate and lower it using the forklift.

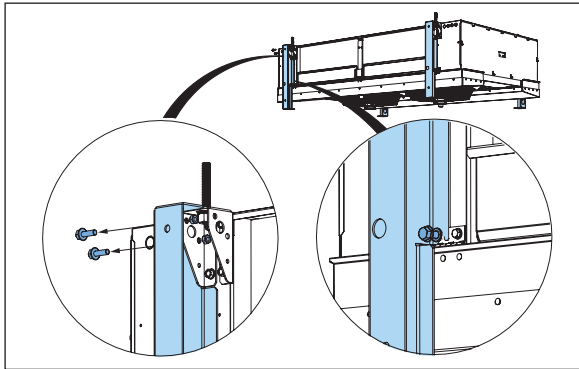

Remove the fixing materials connecting feet to the mounting bracket.  
Loosen the screws connecting feet to the unit.

Remove the transport feet.

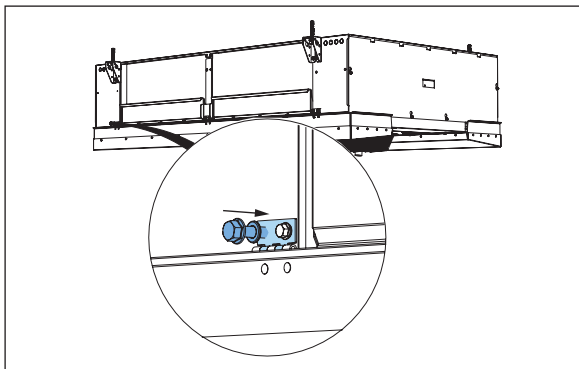

Once the transport feet are removed, tighten the screws on the unit.

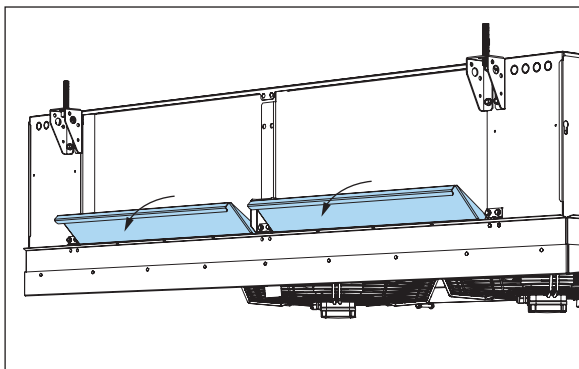

Gently pull down and open the sputter plates.

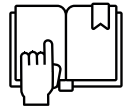

## 5 Installation



Always follow guidelines and instructions as given in the Air coolers product manual.

### 5.1 Mounting dimensions



Detailed drawings showing all required mounting and refrigerant connection dimensions are available for download on Members area.



### 5.2 Mounting bracket

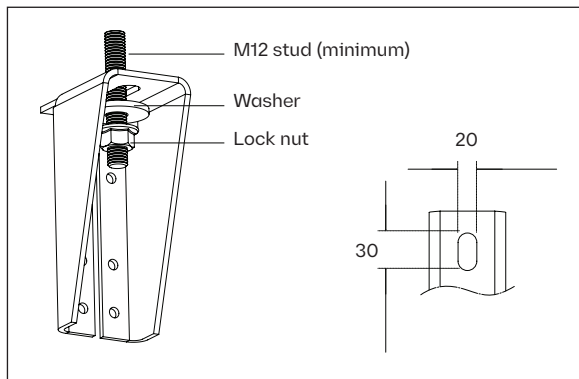

Use extra wide washer (ISO 7093) when mounting the unit to the ceiling. Avoid any lateral torque on the mounting brackets.

### 5.3 Technical spaces

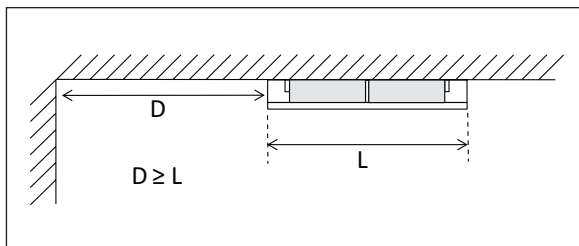

Respect the required minimum space for defrost heater replacement.

### 5.4 Refrigerant connections

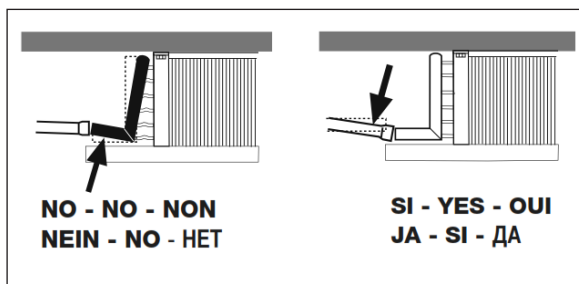

Do not adapt headers position to the suction line. Ensure the supply circuit is closed (no pressure) before connecting the suction lines. Ensure the flame nozzle is not aimed at the equipment, when welding.

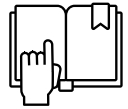

### 5.5 HFC and CO<sub>2</sub> refrigerant

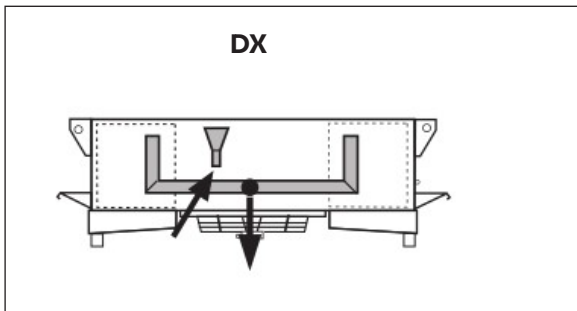

### 5.6 Ammonia refrigerant

The CDA range is suitable for operation with pumped NH<sub>3</sub>. There are two types of supply: pumped top feed PT (default) and pumped bottom feed PB.

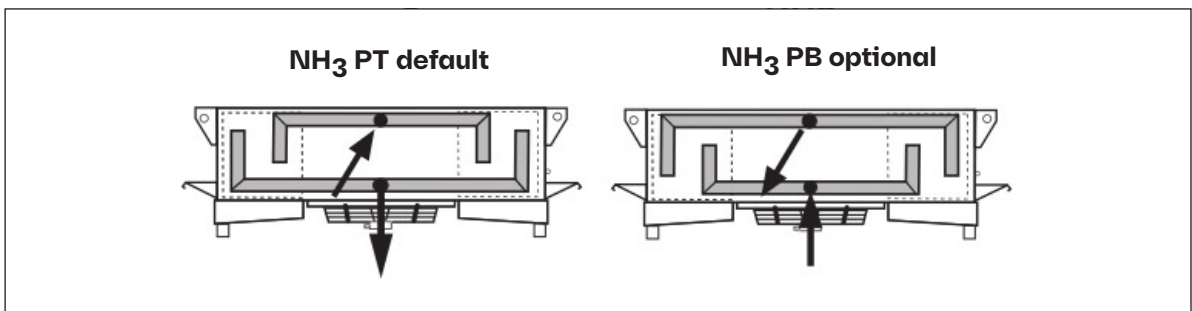

### 5.7 Brine refrigerant

AVA connection is available for brine units.

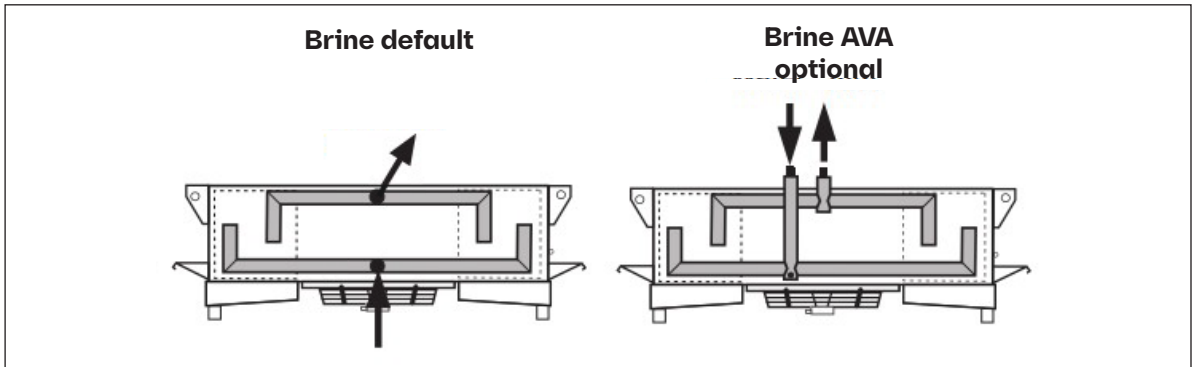

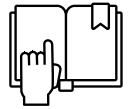

### 5.8 Pressure test

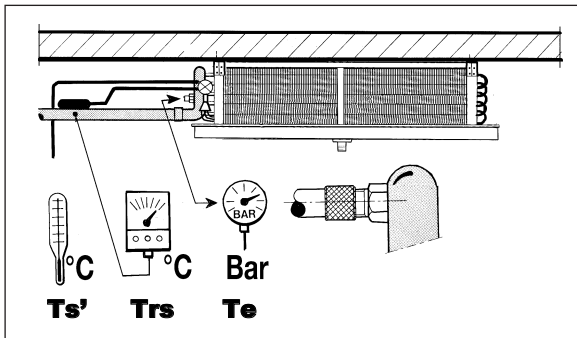

Ts'=cold room air inlet temperature.  
Te=evaporating temperature. It is related to the refrigerant pressure on the air cooler outlet.

Trs=refrigerant superheat temperature, on suction line near thermostatic valve bulb.  
(Trs-Te)=superheat

$$(Trs-Te) \leq 0.7 \times (Ts'-Te)$$

Keep the superheat as low as possible to obtain maximum air cooler performance. The thermostatic valve fitted must be correctly sized for the installation conditions and adjusted for correct system operation.

### 5.9 Drain line



Check all drain lines and drain trays to ensure that no improper material such as, e.g., packaging material blocks the drain.

All pipework should be adequately attached to the walls/ceilings of the cold room and not only to the cooler itself.

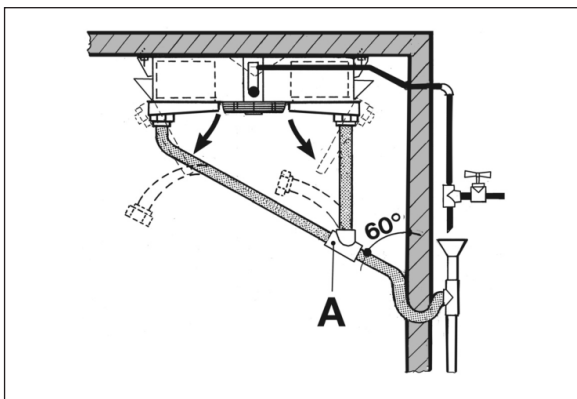

The drain line diameter must be at least the size of the drain tray drain diameter and should be laid with an adequate slope. For room temperatures below 0° C drain line insulation and an internal or external heating element are required to prevent freezing.

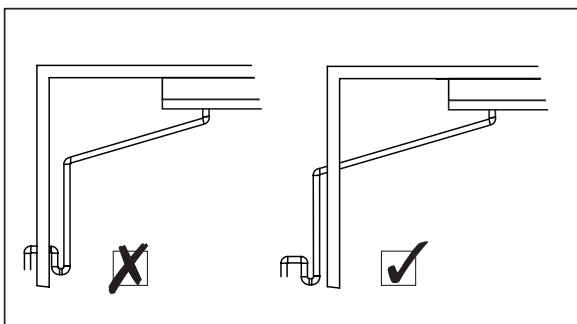

A syphon must be installed on the drain line, outside the cold room.

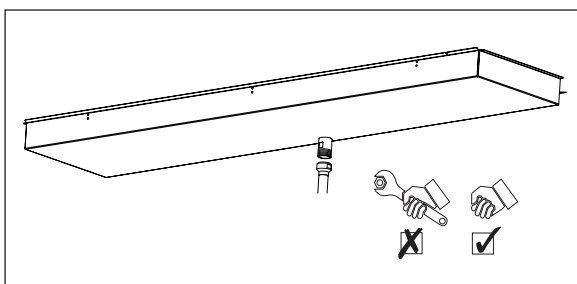

Tighten drain connection by hand only using two wrenches. Keep wrenches firmly to not strain on connection welding.

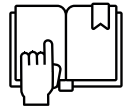

### 5.10 Electrical connections

The heat exchanger shall be installed in conformance with the recognized national standards of electrical and refrigeration installation practice. Ensure complete electrical isolation before performing any wiring.



Electrical connection diagrams for motors and electrical defrost connection for standard units are shown on the following pages as examples. For additional details, please refer to the connection diagrams available for download on Members area.



For special orders units and UL units please refer to order related documents.

The following data determine which connection diagram is to be selected and respected for electrical installation:

- Heat exchanger model indication
- Fan motor type
- Electrical options

When in doubt always contact your local LUVE representative for assistance.



### 5.11 Fan motor connections, AC axial fans

Ø 450 mm

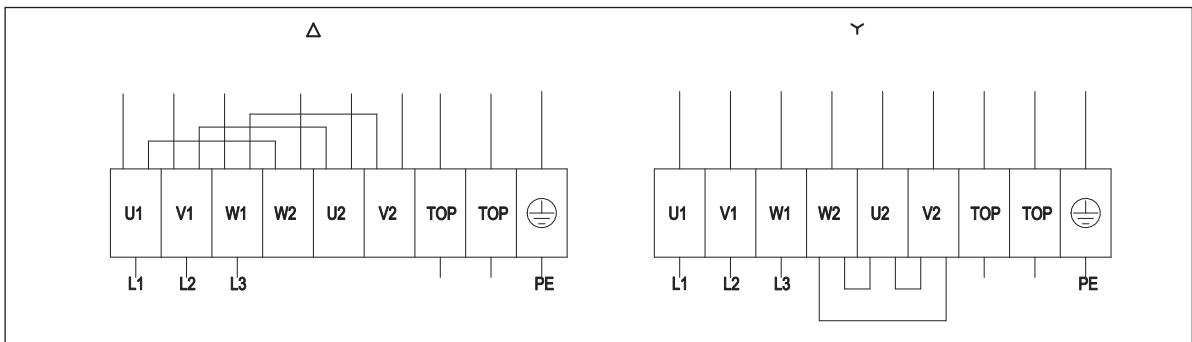

Model	Diameter (mm)	Type	Power supply (V)	Phase	Freq. (Hz)	Connection	Power (W)	Current (A)
CD45	450	AC	400	3ph	50	Δ	480	0.98
CD45	450	AC	400	3ph	50	Y	340	0.58
CD45	450	AC	400	3ph	60	Δ	690	1.2
CD45	450	AC	400	3ph	60	Y	400	0.72
CD45	450	AC	480	3ph	60	Δ	760	1.17
CD45	450	AC	480	3ph	60	Y	520	0.75

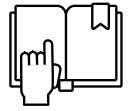

Ø 500, 630 mm

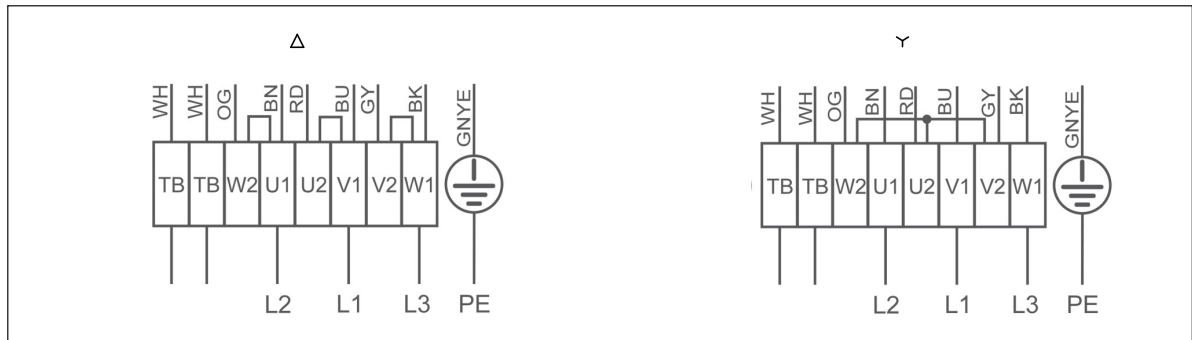

Model	Diameter (mm)	Type	Poles	Power supply (V)	Phase	Freq. (Hz)	Connection	Power (W)	Current (A)
CD50	500	AC	4P	400	3ph	50	Δ	840	1.45
CD50	500	AC	4P	400	3ph	50	Y	540	0.96
CD52	500	AC	6P	400	3ph	50	Δ	290	0.74
CD52	500	AC	6P	400	3ph	50	Y	150	0.36
CD52	500	AC	6P	400	3ph	60	Δ	380	0.88
CD52	500	AC	6P	400	3ph	60	Y	130	0.34
CD52	500	AC	6P	460	3ph	60	Δ	440	0.90
CD52	500	AC	6P	460	3ph	60	Y	180	0.39
CD63	630	AC	6P	400	3ph	50	Δ	620	1.25
CD63	630	AC	6P	400	3ph	50	Y	440	0.72
CD63	630	AC	6P	400	3ph	60	Δ	940	1.6
CD63	630	AC	6P	400	3ph	60	Y	520	0.88
CD63	630	AC	6P	460	3ph	60	Δ	1000	1.55
CD63	630	AC	6P	460	3ph	60	Y	640	0.94
CD64	630	AC	4P	400	3ph	50	Δ	1750	3.7
CD64	630	AC	4P	400	3ph	50	Y	1350	2.2
CD64	630	AC	4P	400	3ph	60	Δ	2800	4.8
CD64	630	AC	4P	400	3ph	60	Y	1800	3
CD64	630	AC	4P	460	3ph	60	Δ	2900	4.6
CD64	630	AC	4P	460	3ph	60	Y	2100	3

During operation with frost of the fins, the power consumption can increase by up to 20-30% more than the nameplate value.

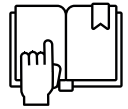

## 5.12 Fan motor connections, EC axial fans

### Ø 450 mm

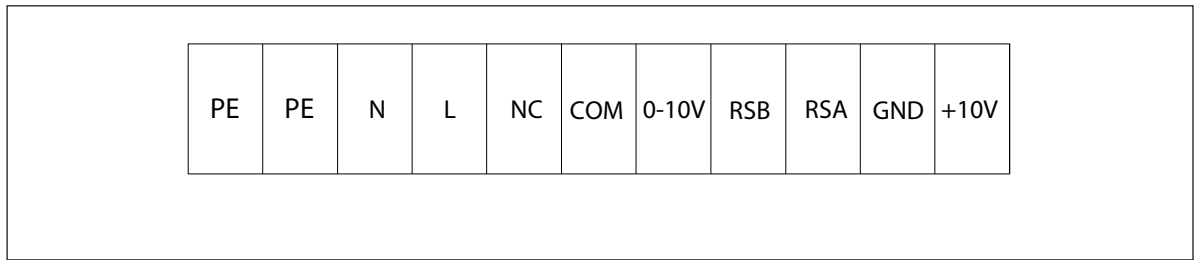

Model	Diameter (mm)	Type	Nominal Voltage range (V)	Phase	Freq. (Hz)	Power Cons. (W)	Current draw (A)
CD45	450	EC	200-277	1ph	50-60	410	1.8

### Ø 500, 630 mm

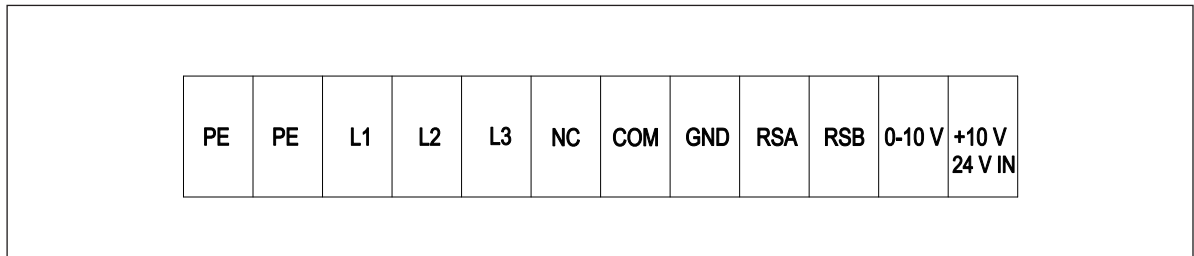

Model	Diameter (mm)	Type	Nominal Voltage range (V)	Phase	Freq. (Hz)	Power Cons. (W)	Current draw (A)
CD50 / CD52	500	EC	380-480	3ph	50-60	630	1
CD63 / CD64	630	EC	380-480	3ph	50-60	1080	1.7

Degree of protection: IP55

Minimum working temperature of EC standard fans: -25 °C.

Contact LUVE, for special version that can reach lower temperature.

Energy saving EC fans are available on request.

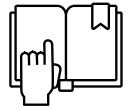

### 5.13 Fan motor connections, EC radial fans

Supplied already pre-wired with an isolator switch.

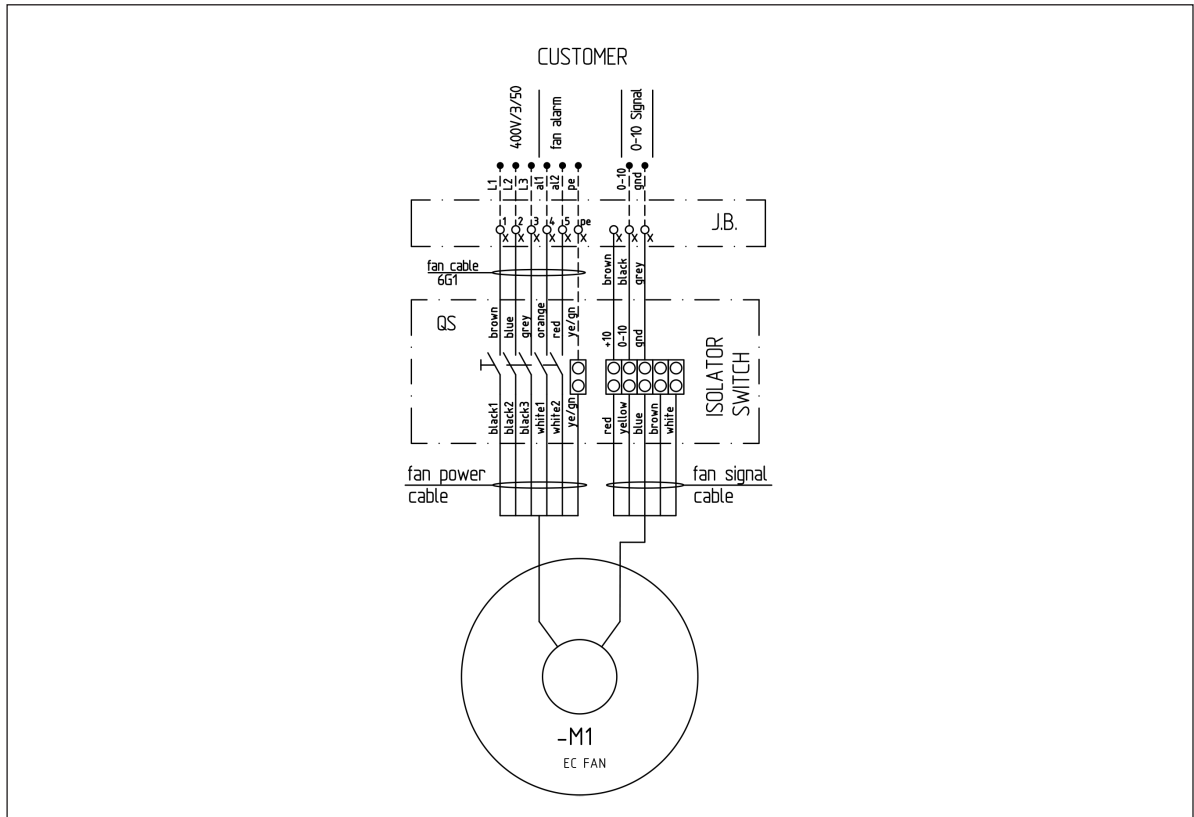

Model	Diameter (mm)	Type	Nominal Voltage range (V)	Phase	Freq. (Hz)	Power Cons. (W)	Current draw (A)
CD63 / CD64	630	EC radial	380-480	3ph	50-60	870	1.35

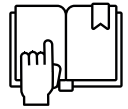

**5.14 Electric defrost**

Ensure complete electrical isolation before performing any wiring.

The following electrical connection diagrams for electrical defrost connection is shown as examples. For additional details for standard units, please refer to the connection diagrams available for download on the Members area.

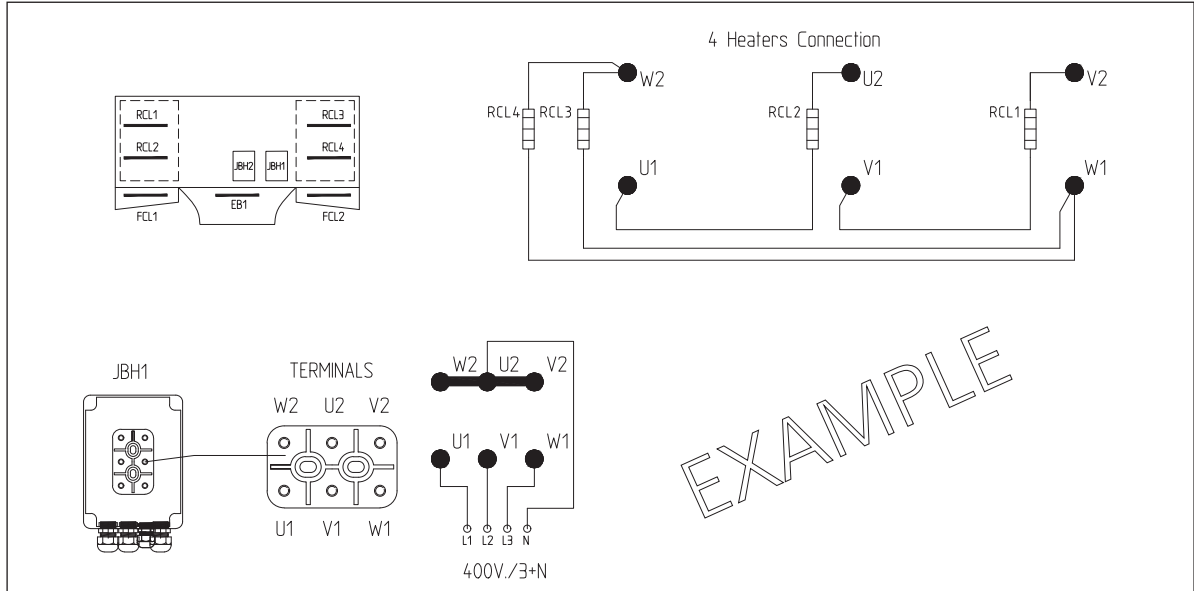

**5.15 Hot-gas connections**

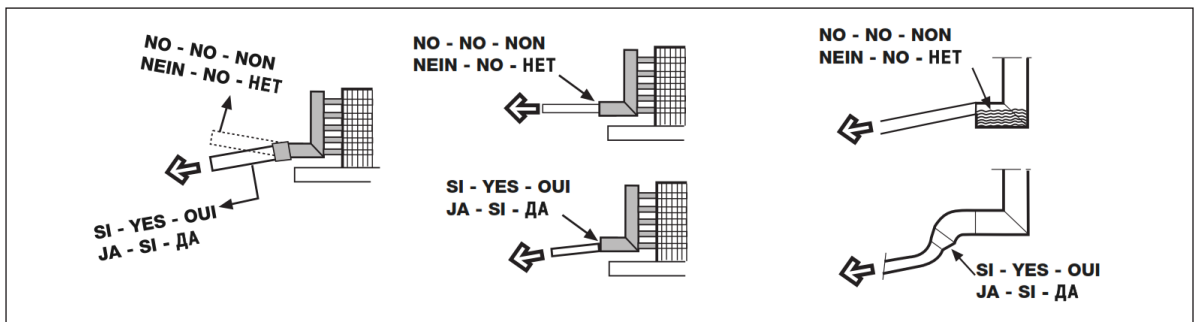

**5.16 Hot-gas defrost (G)**

Hot-gas defrost option features electric defrost in drain tray. For additional details for standard units, please refer to the connection diagrams available for download on the Members area.

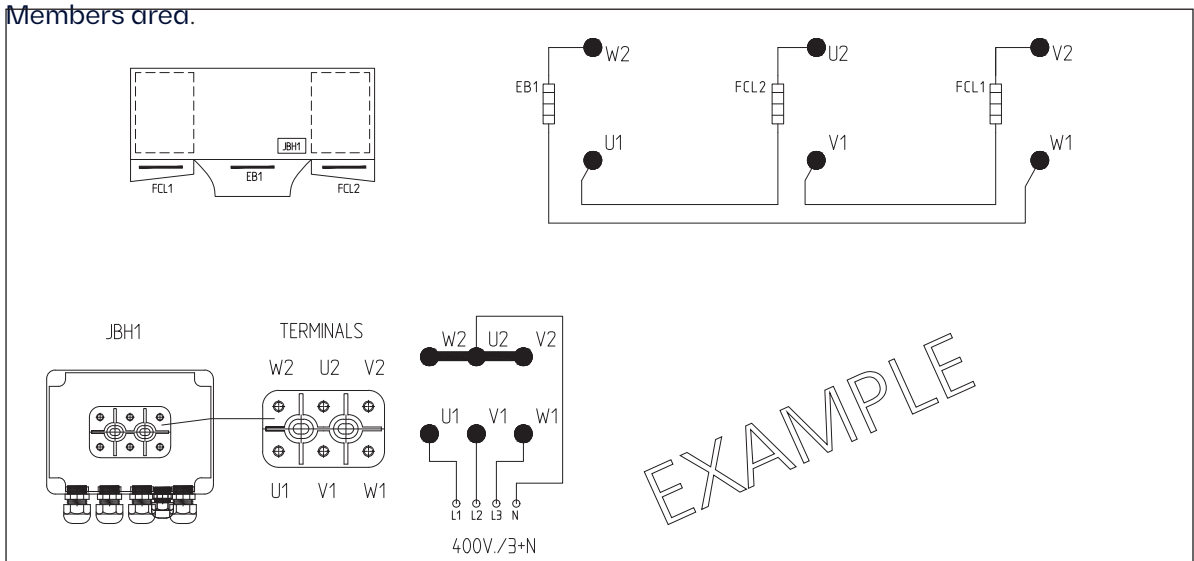

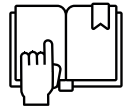

### 5.17 Hot-gas defrost both in coil and drain tray (GB)

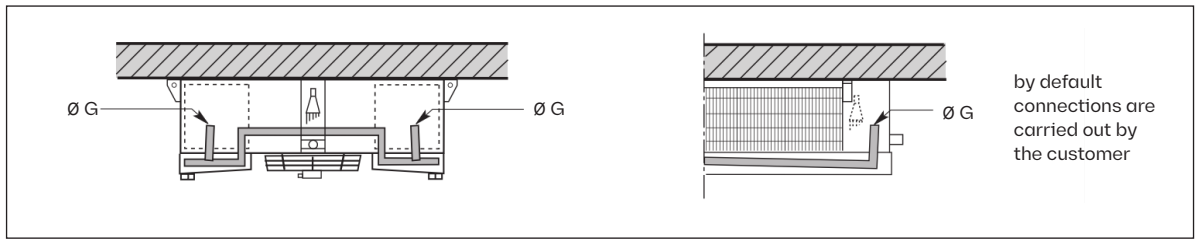

<b>CD45, CD50, CD52</b>	**00	**02	**04	**06	**08	**10	**12	**14
	**50	**52	**54	**56	**58	**60	**62	**64
<b>Fans No.</b>	<b>1</b>	<b>1</b>	<b>2</b>	<b>2</b>	<b>3</b>	<b>3</b>	<b>4</b>	<b>4</b>
<b>Ø G (mm)</b>	28	28	28	28	28	28	28	28

<b>CD63, CD64</b>	**00	*02	*04	**06	**08	**10	**12	**14	**16	**18	**20	**22
	<b>1</b>	<b>1</b>	<b>1</b>	<b>2</b>	<b>2</b>	<b>2</b>	<b>3</b>	<b>3</b>	<b>3</b>	<b>4</b>	<b>4</b>	<b>4</b>
<b>Ø G (mm)</b>	28	28	28	28	28	28	35	35	35	35	35	35

GB is available with an optional double header to reduce pressure drop.

### 5.18 Hot glycol defrost

The hot glycol defrost has a dedicated circuit ( $T_{in} > 30\text{ }^{\circ}\text{C}$ ).

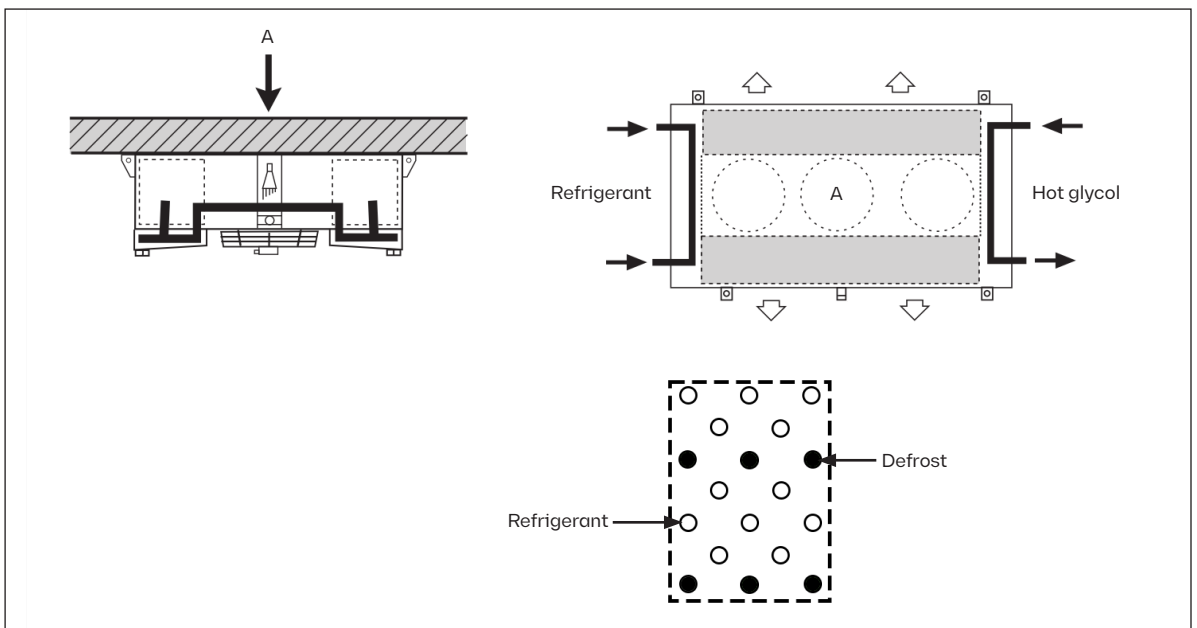

Available versions:

- HG=hot glycol defrost both in coil and drain tray
- HE=hot glycol defrost in coil + electric defrost in drain tray
- HB=hot glycol defrost in drain tray only
- HC=hot glycol defrost in coil only

For HG at low temperature, insulated drain tray is recommended.

As default, the connections are carried out by the customer.

On request, connections can be done by LU-VE.

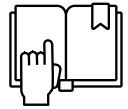

## 6 Maintenance

Ensure complete electrical isolation before performing any maintenance activity and always follow guidelines and instructions as given in the air coolers product manual.

### 6.1 Side panel opening

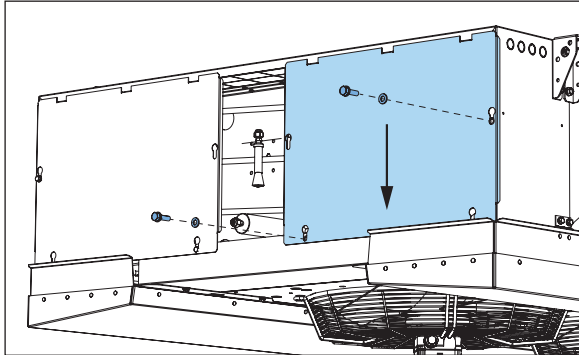

Side panels can be opened for inspection, cleaning and maintenance purposes. This can only be done by qualified personnel. To open the side panels, unscrew fixing materials and remove the panel.

### 6.2 Drain tray opening

Always disconnect drain line before opening the drain tray.

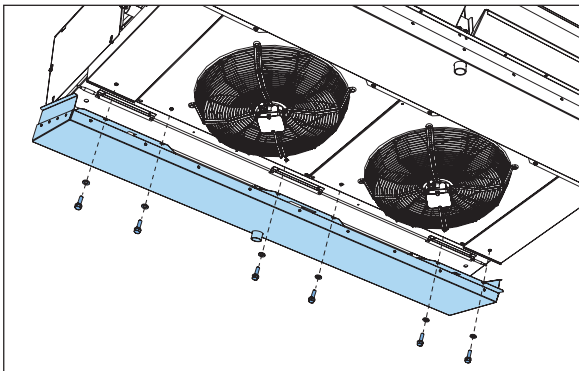

Remove the screws.

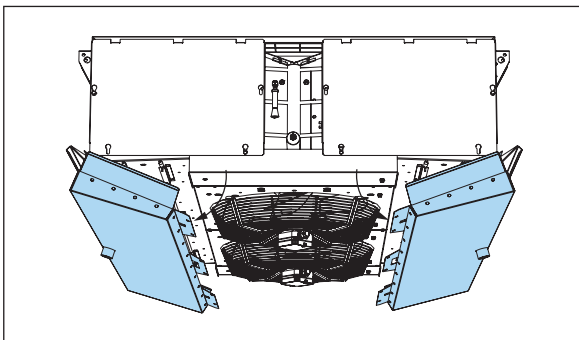

Lower the drain tray. Respect the maximum opening angle (90°) to avoid damage to the drain tray.

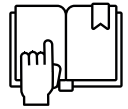

**6.3 Electric defrost elements replacement**

Before handling heater elements always:

- disconnect power supply
- ensure heaters are at ambient temperature.



**Electric defrost elements in coil**

To remove electric defrost elements in coil (RCL and FCL)

- open the side covers on both sides
- disconnect heater element from connection box
- disconnect heater protection, if any
- remove fixing clip (U) and extract element from coil
- mount new element in reverse order and reassemble the fixing clip in the correct position (V)



restore electrical connections and close side covers.

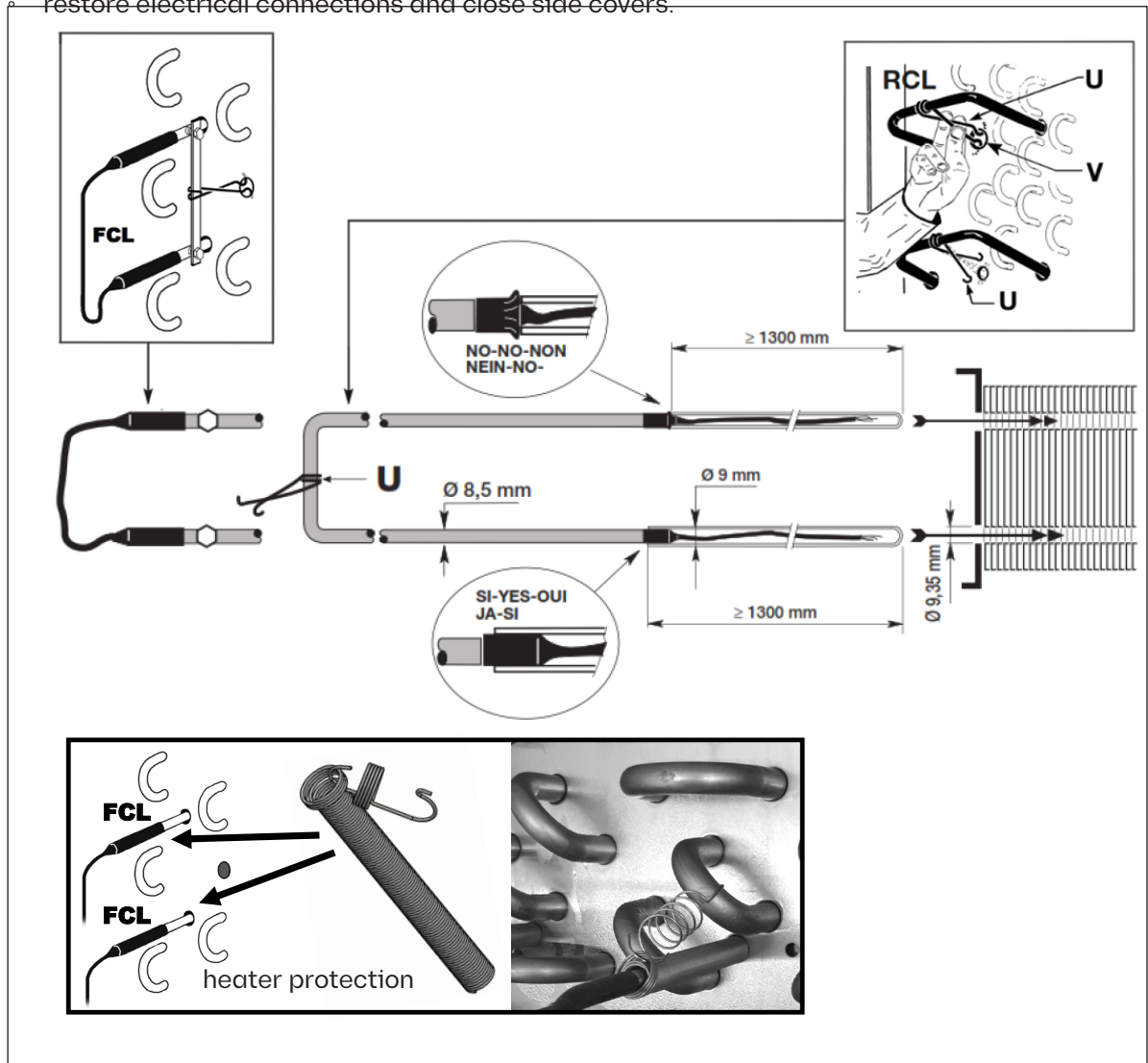

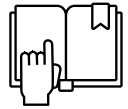

### Electric defrost elements in drain tray

To remove heater elements (FCL) in drain tray:

- open the drain tray
- unscrew fixings and disconnect the heater element
- remove the element
- mount new element in reverse order and fix it to the unit
- close drain tray and restore electrical connections.

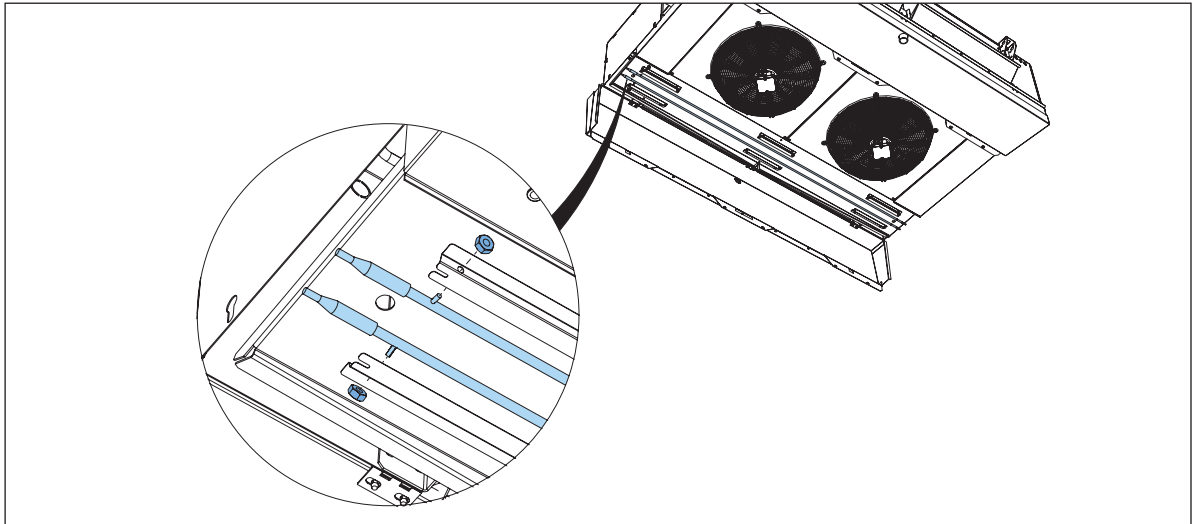

### 6.4 Fan replacement (CD units)

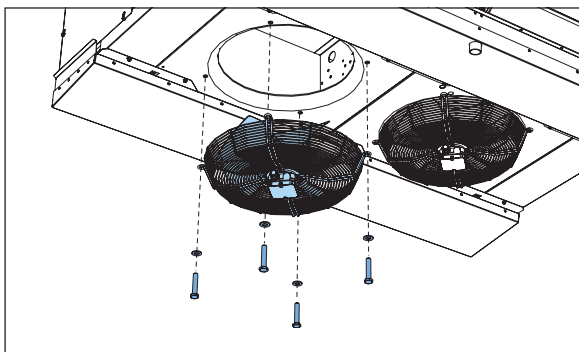

Unscrew fixing bolts. Remove electrical connections and the old fan.

Mount new fan in identical position. Cable glands must be positioned downwards. Use an anti-corrosion compound when remounting the fixing bolts.

Restore electric connection when the new fan has been mounted.

### 6.5 Hinged fan opening (CRD units)



In CRD units, hinged fans can be opened for inspection, cleaning and maintenance purposes. This can only be done by qualified personnel.

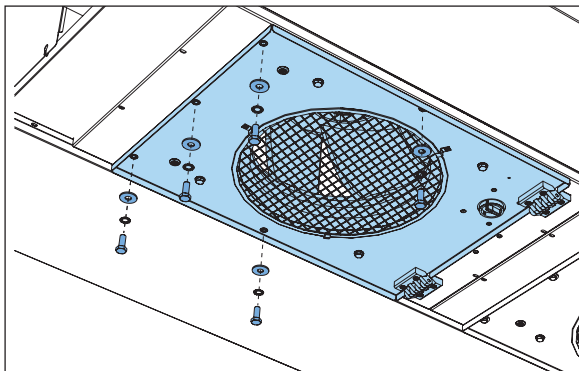

To open the hinged fans, unscrew fixing materials.

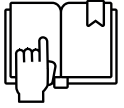

Using a suitable Allen wrench, turn the twist locks 90° inwards.

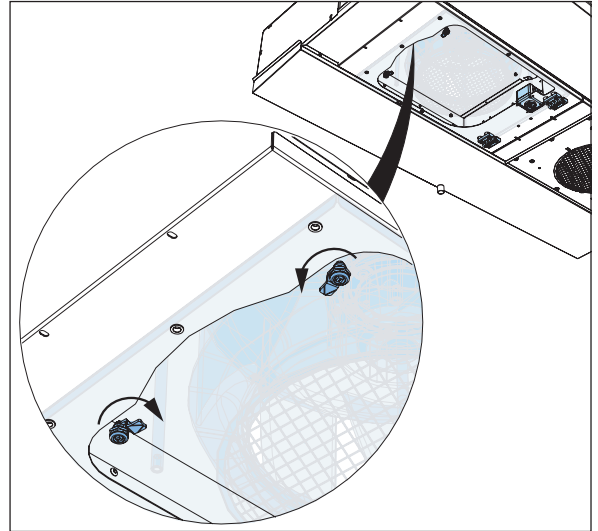
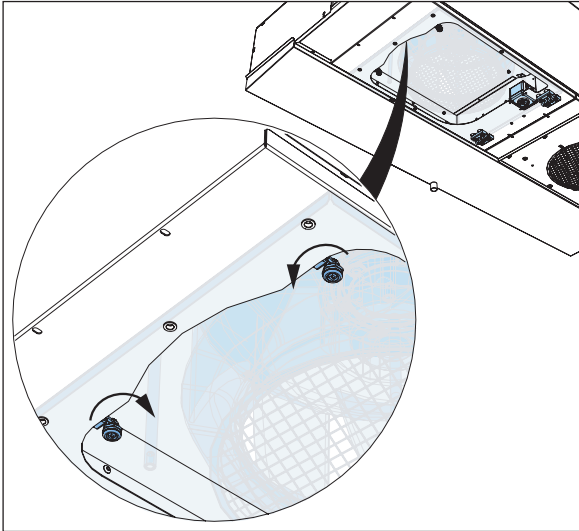

Lower the fan panel.

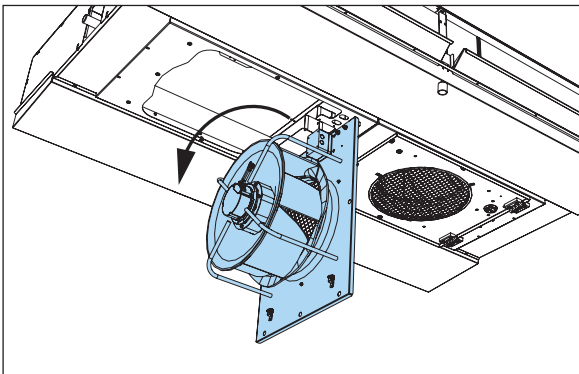

### 6.6 Fan replacement (CRD units)

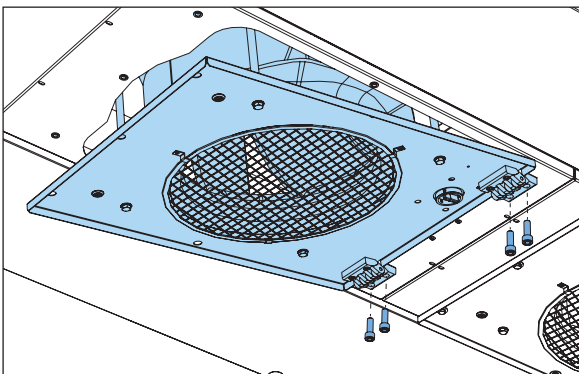

Open the hinged fan. Remove electrical connections.

Unscrew the fixings from the hinges.

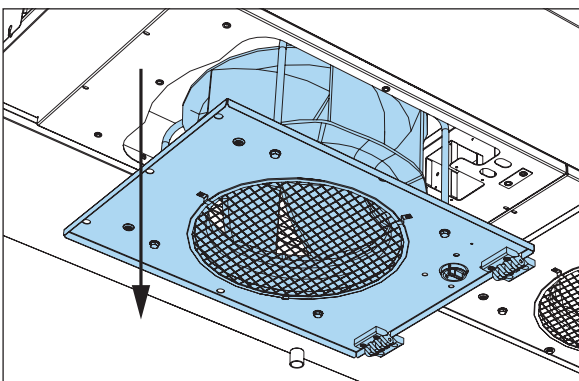

Carefully lower the fan.

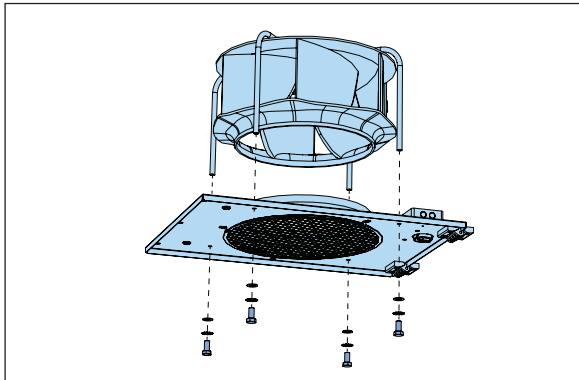
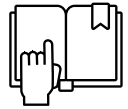

Unscrew the fan motor from the grid panel.

Remove old fan motor.

Mount new fan motor in identical position. Use an anti-corrosion compound when remounting the fixing bolts.

Restore electric connection when the new fan has been mounted.

## 7 Spare parts

Contact your local LUVÉ representative for spare parts order and assistance.

### 7.1 CD units

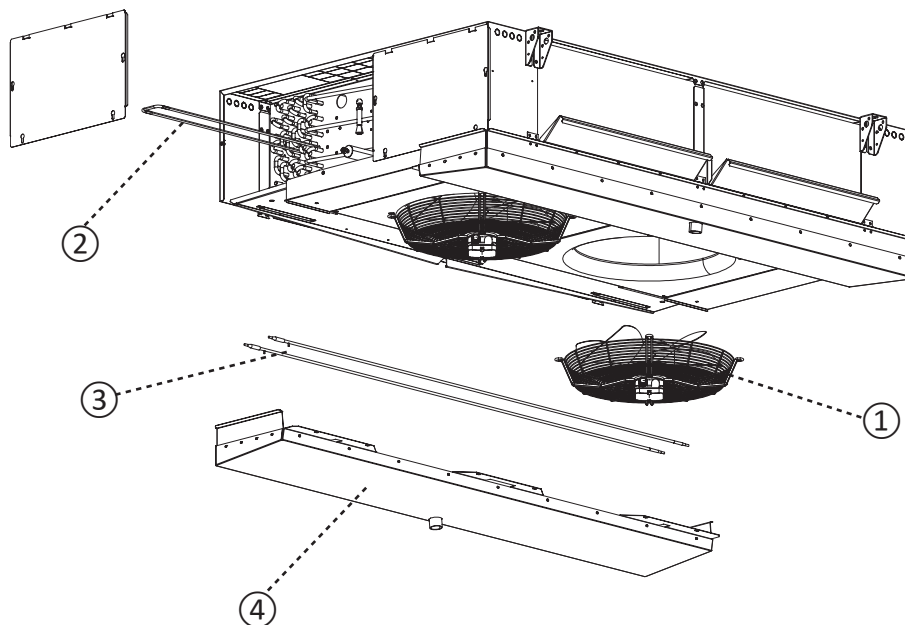

- |   |                                                                                              |
|---|----------------------------------------------------------------------------------------------|
| 1 | Fan motor                                                                                    |
| 2 | Electric defrost in coil (please check scheme "5.13 Fan motor connections, EC radial fans" ) |
| 3 | Electric defrost in drain tray                                                               |
| 4 | Drain tray                                                                                   |

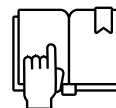

## 7.2 CRD units

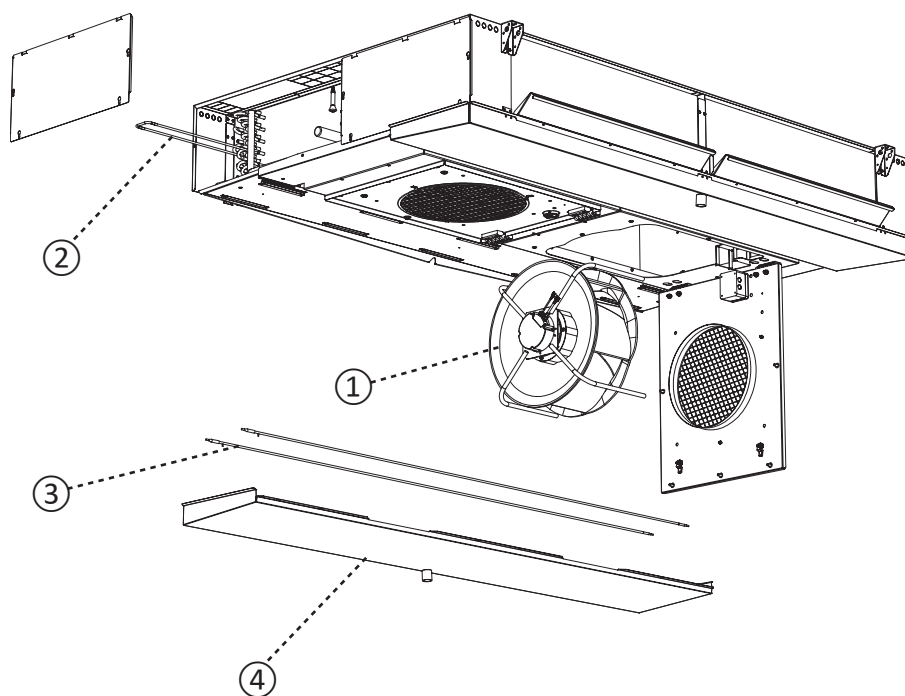

- |   |                                                                                             |
|---|---------------------------------------------------------------------------------------------|
| 1 | Fan motor                                                                                   |
| 2 | Electric defrost in coil (please check scheme "5.13 Fan motor connections, EC radial fans") |
| 3 | Electric defrost in drain tray                                                              |
| 4 | Drain tray                                                                                  |

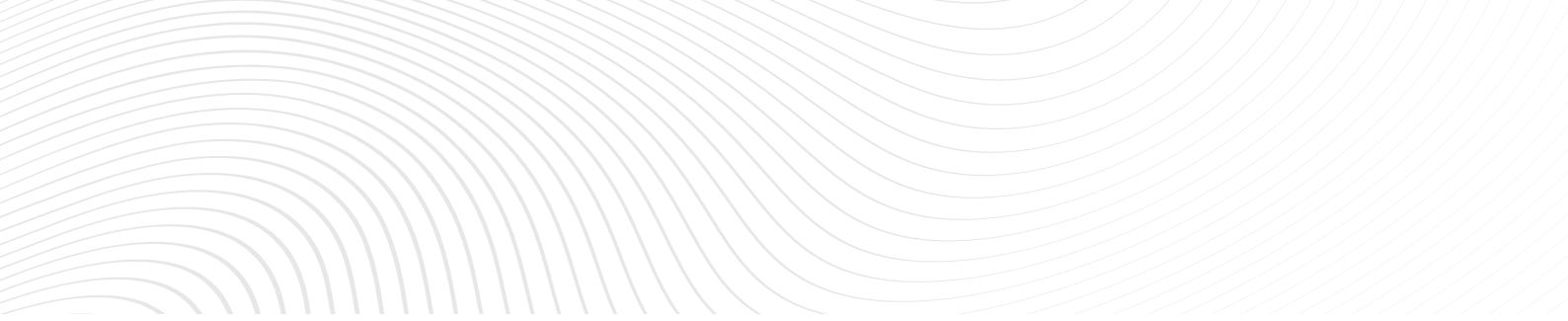

**LU·VE**

**LUVE S.p.A. - The shape of cooling**

Via Caduti della Liberazione, 53 - 21040 Uboldo (VA) - Italy

[www.lu-ve.com](http://www.lu-ve.com)